

5

YEARS
PARTS

2 YEARS LABOUR

All CDA appliances are covered by a 5 year parts and 2 year labour warranty for **complete peace of mind**.*

*See terms and conditions for more details.

All CDA sinks and taps are covered by a 5 year parts warranty*. Labour/fitting costs are not included unless under exceptional circumstances.

All warranties are subject to registration within 60 days of purchase - register online at www.cda.eu or complete the form inside your appliance.



|C|D|A|

Appliances | Sinks | Taps

5

YEARS
PARTS

2 YEARS LABOUR



Contact us for more information

The Sales Department: **01949 862010**

The Customer Care Department: **01949 862012**

www.cda.eu

The **CDA Group Ltd.** Harby Road, Langar, Nottinghamshire, NG13 9HY T: **01949 862 000** F: **01949 862 001** E: sales@cda.eu

Distributed in Ireland by: **Bodel Distributors**, Hulls Lane, Lisburn, BT28 2SR T: **048 9267 2412** F: **048 9267 1873** W: www.bodel.com
Distributed in Pakistan by: **Chughtaiz**, Lahore, Pakistan T: **+92 42 3578 2891 2** W: www.chughtaiz.com | Part of the **Amica Group**

|C|D|A|

Welcome to **your** kitchen

Kitchen Retail Brochure 2020

September 2020





Why choose CDA?

Our assurance of quality

Our on-site testing laboratory ensures that only safe, reliable products are brought to market. We test to the British consumers' exacting standards without compromise.

Dedicated engineers

We use our own dedicated service engineers, equipped with a large range of CDA spare parts allowing them to achieve an excellent first time fix rate.

Over 25 years' experience

Established for over 25 years, CDA have built a reputation for stylish, innovative and award-winning products that consistently deliver outstanding results.

Part of the Amica Group PLC

In December 2015, CDA became part of the Amica Group. Amica, a kitchen appliance manufacturer based in Poland, operate in 50 countries worldwide and have over 70 years' experience in the industry.

CDA share the same vision of providing the best products possible, as well as our values of good environmental practice, and together we can deliver even more for customers.

In-house customer care

Our in-house Customer Care Department, based at our head office in Nottinghamshire, is made up of highly knowledgeable and experienced staff who will support you throughout the lifetime of your product.

More deliveries to you

CDA deliver to retailers and kitchen studios daily so your new appliances will arrive quickly. All of our stock is held at our warehousing facilities in Nottinghamshire which are ideally located to ensure efficient and fast distribution across the UK.

Amica
for living



“Quality is something we respect and strive for in our products, our people and our service.

Our reputation is built on delivering genuine quality through those three foundations every single day.”

Ian Kershaw
CDA founder and Chairman

Contents

COOKING

Single ovens	10 - 19
Compacts	20 - 29
Double ovens	30 - 33
Hobs	34 - 61
Gas hobs	40 - 47
Electric hobs	46 - 61
Extractors	62 - 77

COOLING

Refrigeration	78 - 93
Wine coolers	94 - 101

WASHING

Dishwashers	102 - 109
Laundry	110 - 115

SINKS AND TAPS

Sinks	116 - 149
Taps	150 - 163

ACCESSORIES	164 - 173
--------------------	------------------

Oven functions explained

Our ovens come with a wide selection of functions to help you cook your meal to perfection every time.



Oven light

This illuminates the oven cavity for easy viewing of food during cooking.



Defrost

Using the fan only, this oven function circulates the air around the oven cavity, speeding up the natural defrosting process.



Conventional oven/ Eco conventional oven

This function uses the top and bottom heating elements only. Natural convection creates a perfect cooking zone in the centre of the oven, ideal for dark fruit cakes and pastries.

The Eco setting on the fan oven or conventional oven uses residual heat to finish cooking your meal, saving energy.



Fan oven/Eco fan oven

Using the circular heating element and the fan, this cooking function circulates heated air around the oven cavity; temperatures are achieved quickly reducing the need for preheating. Both cooking temperature and cooking time can be reduced for a more energy-efficient cooking programme. This is perfect for cooking various food types simultaneously as foods are sealed quickly to prevent flavour transfer.

The Eco setting on the fan oven or conventional oven uses residual heat to finish cooking your meal, saving energy.



Fan-assisted oven

Using the fan to circulate the heat produced by the top and bottom heating elements, this function distributes the heat around the oven to give an even temperature throughout.



Fan cooking with lower heat

Using the fan element to enhance the main heat being produced by the lower heating element, this function is perfect for cooking pizzas.



Fan cooking with upper heat

Uses the fan element and the top element to create a gentle heat, ideal for reheating already cooked foods or keeping food warm.



Fan with lower heat

The fan circulates the heat produced by the bottom heating element, ideal for one-pot dishes such as casseroles or curries.



Browning oven

The perfect finishing touch. Using the top element only, this function browns and crisps food with conventional heat. This is ideal for cauliflower or macaroni cheese.



Warming oven

Using heat produced only by the bottom element, this natural heat is perfect for proving dough and blind baking.



Eco clean/ Aqualytic clean

The Eco setting creates hot steam from water in the oven tray to loosen dirt and grease.

The Aqualytic cleaning function uses water to steam clean the interior of your oven, loosening grease and dirt from the enamel.



Full grill/Half grill

This fully variable grill is ideal for grilling a full family meal.

Selected ovens offer a half grill option, using just the centre section for grilling smaller quantities.



Fanned electric grill/Fanned half electric grill

This uses the grill element and the fan to circulate the heat around the food.

Selected ovens offer a half fanned grill option, using just the centre section for grilling smaller quantities.



Steam cooking

Cooking with the power of steam alone locks more nutrients into your food. Steaming is the healthier option for cooking meat, fish, vegetables and fruits.



Pyrolytic cleaning

This function raises the temperature of your oven to 450°C, reducing any food deposits to a fine ash which can then be easily wiped away from the oven interior.

Full pyrolytic clean - 2 hours.



Gas oven

Heat rises from the gas burner at the base of the oven. This method of cooking (hot at the bottom, cooler at the top) is perfect for family meals, as foods can be cooked at different temperatures at the same time.



Rapid preheat

Select the Rapid Preheat function to boost power to your oven and bring it up to baking temperature in under 5 minutes.



Steam clean

Use this cleaning function to harness the natural power of steam and loosen dirt and grease from your oven cavity, without the use of harsh chemicals.



Gas grill

This variable gas grill is used with the door ajar, giving you perfect results when grilling chops, burgers and sausages.



Fanned gas oven

Heat rises from the gas burner at the base of the oven and is distributed by a fan, creating an even cooking temperature.



Microwave function

Food is cooked from the outside in using microwaves, making this style of cooking quick and convenient.



Microwave and grill

Food is cooked from the outside in using microwaves with the added feature of the grill browning the food.



Microwave and fan oven

Food is cooked using microwaves and browned on the outside by the fan oven.



Microwave, grill and fan oven

This function combines the microwave function and the fan oven to cook food thoroughly and brown the top for a perfect oven finish.

5

**YEARS
PARTS**

2 YEARS LABOUR





Single ovens

Our expertise in appliance manufacturing means that whichever stylish model you choose, you can be certain of high performance, advanced technology and reliability.

New aesthetics

The new design is carried throughout the range with updated steel accents, white LED displays and a 96mm control panel. These updates bring the collection to the foreground of kitchen appliance design.

Soft close

The soft close action brings a high quality feel to the day to day experience of using these ovens. The attention to detail here demonstrates the thought and design that has gone into other aspects of the technology that runs through the whole range.

Rapid preheating

Reach temperatures of 150°C in just 4 minutes with the rapid preheating available on most models.

Lateral lighting

Get to see everything you are cooking with our lateral lighting, standard across all of our SL range.

Large cavity

With a huge 77L oven capacity these models have plenty of room for the whole roast dinner. This takes the pressure off in the kitchen and ensures that our customers can rely on their oven to meet any challenge they throw at it.

Full steam oven

The SL670 features full steam cooking, has multifunctional oven function options as well as the ability to combine the best of both with its combination steam auto programmes. This helps the cook create tender meat dishes, vibrant and fresh vegetables and even rival professional bakeries with crusty loaves or beautifully risen cakes.

Pre-set programmes

There is a recipe book of pre-set programmes built into these intelligent ovens that offers cooks tried and tested settings and timings to help them produce perfect results at every mealtime.

Quick guide to single ovens

The CDA range offers a wide choice of designs. Each oven has an energy rating of A & A+, alongside built-in safety features, including anti-tilt shelving to reduce accidents when removing hot food from the oven.



More space

Products with the icon above have an extra-large cavity with a net capacity of 77L. Extra space and additional shelf positions mean you can achieve better cooking results even with a full oven. All of our SL range carry a space saver shelf as standard, allowing you to use the space at the bottom of your cavity.



Self-cleaning

Our **pyrolytic oven** range has a self-cleaning programme that enables the oven to clean itself.

The programme automatically locks the oven door for safety, then heats the internal oven cavity to over 450°C to incinerate residual cooking fat and spills to a fine ash. You can then simply wipe the ash away once the cycle has finished. Each cycle costs around 45p - much cheaper than branded oven cleaners.

Single ovens



SL100

- 7 functions
 - 77L net capacity
- Details on [p14](#)



SL200

- 7 functions
 - 77L net capacity
- Details on [p14](#)

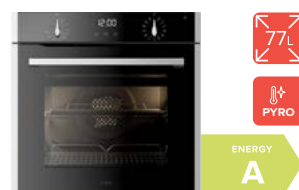

SL500

- 13 functions
 - 77L net capacity
 - Pyrolytic cleaning
- Details on [p16](#)



SL550

- 13 functions
 - 77L net capacity
 - Pyrolytic cleaning
- Details on [p16](#)



SG120

- 5 function gas oven
 - 56L net capacity
 - Stainless steel
- Details on [p18](#)



SC621

- 7 functions
 - 59L net capacity
- Details on [p18](#)



SL300

- **12 functions**
- 77L net capacity
- Details on **p15**



SL400

- **13 functions**
- 77L net capacity
- Details on **p15**

See **pages 20 - 29**
for all our matching
compact appliances



SL570

- **13 functions**
- 77L net capacity
- Pyrolytic cleaning
- Details on **p17**



SL670

- **13 functions**
- 77L net capacity
- Steam cooking
- Details on **p17**

Single ovens



SL100

Seven function electric fan oven

Features

- 0 set lateral halogen lights
- Cooling fan
- Chromed rack sides with integrated anti-tilt shelves
- 6 shelf positions
- Triple glazed removable door with removable inner glass for easy cleaning
- Easy clean enamel interior

Accessories

- 1 easy clean flat oven shelf
- 1 space-saver shelf
- 1 grill pan with grid

Available in stainless steel

Energy efficiency rating: A

Technical specification

Rated electrical power: **2.8kW**
 Power supply required: **13A**
 Total usable capacity: **77L net**

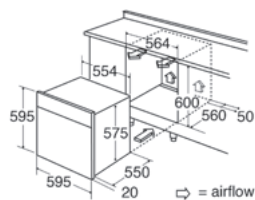

SL200

Seven function electric fan oven

Features

- Touch control programmable clock/timer
- White LED display
- 0 set lateral halogen lights
- Cooling fan
- Chromed rack sides with integrated anti-tilt shelves
- 6 shelf positions
- Triple glazed removable door with removable inner glass for easy cleaning
- Easy clean enamel interior

Accessories

- 1 easy clean flat oven shelf
- 1 space-saver shelf
- 1 grill pan with grid

Available in stainless steel

Energy efficiency rating: A

Technical specification

Rated electrical power: **2.8kW**
 Power supply required: **13A**
 Total usable capacity: **77L net**

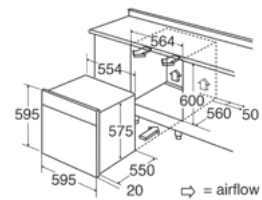

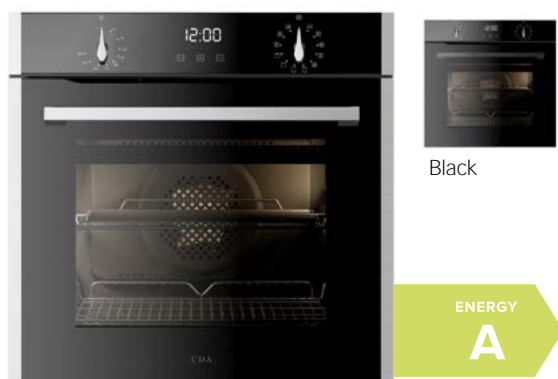

Stainless steel



SL300

Twelve function multifunction oven

Features

- Touch control programmable clock/timer
- White LED display
- O set lateral halogen lights
- Cooling fan
- Chromed rack sides with integrated anti-tilt shelves
- 6 shelf positions
- Triple glazed removable door with removable inner glass for easy cleaning
- Soft close door
- Easy clean enamel interior

Accessories

- 1 easy clean flat oven shelf
- 1 space-saver shelf
- 1 grill pan with grid
- 1 x 75% telescopic shelf

Available in stainless steel, black

Energy efficiency rating: A

Technical specification

Rated electrical power: **2.8kW**

Power supply required: **13A**

Total usable capacity: **77L net**

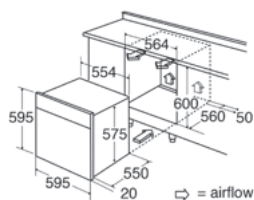

SL400

Thirteen function multifunction oven

Features

- Full intuitive touch control
- White LED display
- Preset recipes
- 3pc catalytic liners
- O set lateral halogen lights
- Cooling fan
- Safety key lock
- Chromed rack sides with integrated anti-tilt shelves
- 6 shelf positions
- Soft close door
- Triple glazed removable door with removable inner glass for easy cleaning
- Easy clean enamel interior

Accessories

- 1 easy clean flat oven shelf
- 1 space-saver shelf
- 1 grill pan with grid
- 2 x 75% telescopic shelves

Available in stainless steel

Energy efficiency rating: A+

Technical specification

Rated electrical power: **2.8kW**

Power supply required: **13A**

Total usable capacity: **77L net**

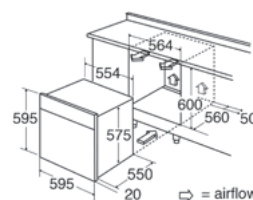

Single ovens



SL500

Thirteen function pyrolytic oven

Features

- Touch control programmable clock/timer
- White LED display
- Pyrolytic function
- O set lateral halogen lights
- Cooling fan
- Chromed rack sides with integrated anti-tilt shelves
- 6 shelf positions
- Quadruple glazed removable cool door with removable inner glass for easy cleaning
- Easy clean enamel interior

Accessories

- 1 easy clean flat oven shelf
- 1 space-saver shelf
- 1 grill pan with grid

Available in stainless steel

Energy efficiency rating: A

Technical specification

Rated electrical power: **2.8kW**
Power supply required: **13A**
Total usable capacity: **77L net**

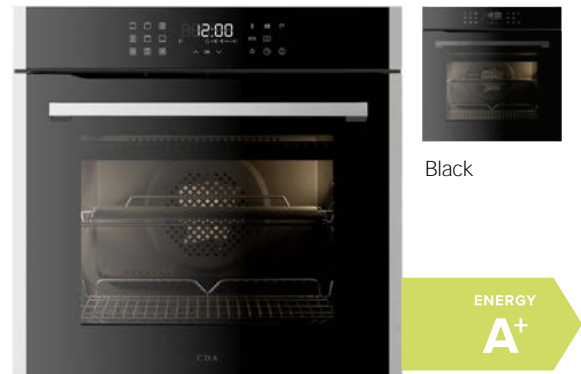
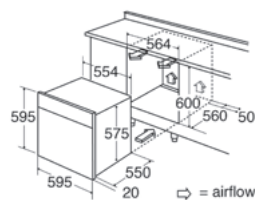

Stainless steel



SL550

Thirteen function pyrolytic oven

Features

- Full intuitive touch control
- White LED display
- Pyrolytic function
- Preset recipes
- O set lateral halogen lights
- Cooling fan
- Safety key lock
- Chromed rack sides with integrated anti-tilt shelves
- 6 shelf positions
- Soft close door
- Quadruple glazed removable door with removable inner glass for easy cleaning
- Easy clean enamel interior

Accessories

- 1 easy clean flat oven shelf
- 1 space-saver shelf
- 1 grill pan with grid
- 2 x 75% telescopic shelves

Available in stainless steel, black

Energy efficiency rating: A+

Technical specification

Rated electrical power: **2.8kW**
Power supply required: **13A**
Total usable capacity: **77L net**

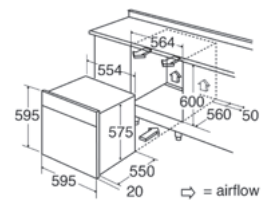



SL570

Thirteen function pyrolytic oven

Features

- Full intuitive touch control
- White LED display
- Pyrolytic function
- Temperature probe
- Preset recipes
- O set lateral halogen lights
- Cooling fan
- Safety key lock
- Chromed rack sides with integrated anti-tilt shelves
- 6 shelf positions
- Soft close door
- Quadruple glazed removable door with removable inner glass for easy cleaning
- Easy clean enamel interior

Accessories

- 1 easy clean flat oven shelf
- 1 space-saver shelf
- 1 grill pan with grid
- 1 extra deep roasting tray
- 2 x 75% telescopic shelves

Available in stainless steel

Energy efficiency rating: A+

Technical specification

Rated electrical power: **2.8kW**
Power supply required: **13A**
Total usable capacity: **77L net**

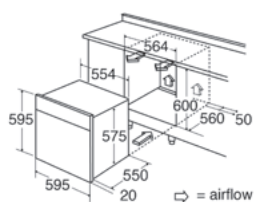

SL670

Thirteen function steam oven

Features

- Full intuitive touch control
- White LED display
- Full steam cooking
- Multifunction cooking
- Combination steam cooking
- Temperature probe
- Preset recipes
- 3pc catalytic liners
- O set lateral halogen lights
- Cooling fan
- Safety key lock
- Chromed rack sides with integrated anti-tilt shelves
- 6 shelf positions
- Soft close door
- Triple glazed removable door with removable inner glass for easy cleaning
- Easy clean enamel interior

Accessories

- 1 easy clean flat oven shelf
- 1 space-saver shelf
- 1 grill pan with grid
- 1 extra deep roasting tray
- 2 x 100% telescopic shelves

Available in stainless steel

Energy efficiency rating: A+

Technical specification

Rated electrical power: **2.8kW**
Power supply required: **13A**
Total usable capacity: **77L net**

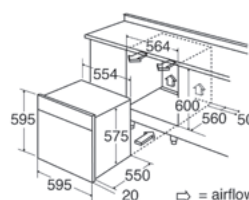

Single ovens



SG120

Five function gas oven

Features

- 60 minute minder
- Interior light
- Cooling fan
- Chromed rack sides with integrated anti-tilt shelves
- Double glazed removable door with removable inner glass for easy cleaning
- Flame failure safety device included
- Easy clean enamel interior

Accessories

- 2 flat oven shelves
- 1 grill pan with grid
- LPG conversion kit included

Available in stainless steel

Technical specification

Rated gas input: **2.7kW**
 Rated electrical power: **60W**
 Power supply required: **3A**
 Total usable capacity: **56L net**

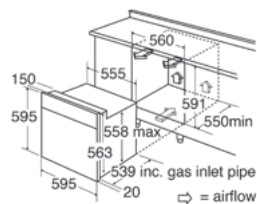

SC621

Seven function electric side opening oven

Features

- Touch control programmable clock/timer
- White LED display
- Interior halogen light
- Cooling fan
- Chromed rack sides with integrated anti-tilt shelves
- Triple glazed removable cool door with removable inner glass for easy cleaning
- Reversible side opening door
- Easy clean enamel interior

Accessories

- 2 flat oven shelves
- 1 grill pan with grid

Available in stainless steel

Energy efficiency rating: A

Technical specification

Rated electrical power: **2.16kW**
 Power supply required: **13A**
 Total usable capacity: **59L net**

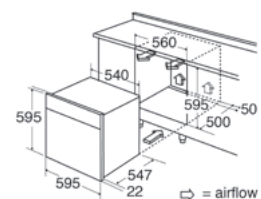



Single ovens



5

YEARS
PARTS

2 YEARS LABOUR

Compacts

In our compacts range you'll find a selection of useful and innovative appliances that add functionality and that special finishing touch to your kitchen.

Drawers

A warming drawer is ideal for warming plates, proving dough, melting chocolate, making yoghurt and keeping cooked food warm. These are so useful that once you've had one you'll never want to do without!

Choose between a 'push-push' open and close action, where you press the drawer surface to make it slide open and again to close it, or a traditional ergonomic handle design to finish your kitchen.

Compact ovens

Our compact range offers a steam oven and a compact combination oven and microwave model. The **VK903** provides a grill, microwave and a fan oven all in one neat appliance, making it the perfect choice for kitchens where space is limited.

Compact coffee maker

The **VC820** automatic coffee maker will make mornings worth waking up for. This built-in 60cm coffee maker features our hallmark sleek styling and now offers Procino, an automatic latte and cappuccino maker.

It comes with full touch control and multiple grind settings, along with adjustable coffee strength and quantities to make your perfect hot drink. You can use coffee beans or pre-ground coffee with this machine, making it truly flexible to your lifestyle.

Steam cooking

Now with full touch control, the **VK703SS** offers healthy, vitamin-preserving cooking at home. The refillable reservoir means that there is no need to connect to the mains water supply and the combination grill allows you to brown food for an appetising finish.

Quick guide to compact cooking and microwaves

These versatile compact appliances look stunning when installed together as a bank. Install warming drawers beneath for ultimate cooking flexibility.

We have a choice of microwaves to suit your requirements. Freestanding and built-in options are available.

Microwaves



VM101

- **Freestanding microwave oven and grill**
- LED timer and clock
- Quick start
- Details on [p24](#)



VM201

- **Freestanding microwave oven and grill**
- LED timer and clock
- Quick start
- Details on [p24](#)



VM131

- **Built-in microwave oven**
- LED timer and clock
- Quick start
- Stainless steel or black
- Details on [p25](#)



VM231

- **Built-in microwave oven and grill**
- LED timer and clock
- Quick start
- Stainless steel or black
- Details on [p25](#)



VM452

- **Built-in microwave oven, grill and convection oven**
- LED timer and clock
- Auto defrost
- Quick start
- Details on [p26](#)



VM551

- **Wall unit microwave oven**
- LED timer and clock
- Auto defrost
- Quick start
- Details on [p26](#)

Compact refrigeration

Please see our refrigeration section for the following compact refrigeration products:

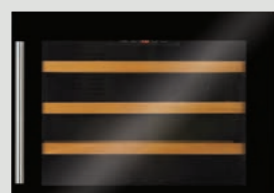

FWV452

- Built-in compact wine cooler
- Details on [p101](#)

Compact appliances



VK703

- **Compact steam oven and grill**
- Full touch control
- LED display
- Details on [p27](#)



VK903

- **Compact combination microwave, grill and fan oven**
- Full touch control
- LED display
- Details on [p27](#)



VC820

- **Compact coffee maker**
- 5 coffee strength settings
- Touch control
- Stainless steel or black
- Details on [p28](#)

Drawers



VW143

- **Warming drawer**
- 6 place settings
- Variable temperature
- Smooth runners
- Details on [p29](#)



VW153

- **Push-push warming drawer**
- 6 place settings
- Variable temperature
- Smooth runners
- Details on [p29](#)

Microwaves



VM101

Freestanding microwave oven

Features

- Microwave function
- Auto defrost
- Quick start
- LED timer and clock
- 5 microwave power levels - 900W max.
- Interior lateral light
- Acoustic end of programme signal
- Left-hand hinged door
- Safety key lock

Accessories

- Glass turntable - 315mm diameter
- Turntable ring

Available in stainless steel

Technical specification

Total usable capacity: **25L net**
 Rated electrical power: **1.45kW**
 Power supply required: **13A**

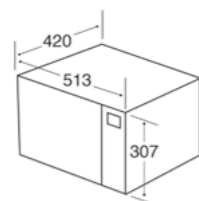

VM201

Freestanding microwave oven and grill

Features

- Microwave function
- Grill function
- Microwave/grill function
- Auto defrost
- Quick start
- LED timer and clock
- 5 microwave power levels - 900W max.
- Grill rating - 1kW
- Interior lateral light
- Acoustic end of programme signal
- Left-hand hinged door
- Safety key lock

Accessories

- Glass turntable - 315mm diameter
- Turntable ring
- Trivet

Available in stainless steel

Technical specification

Total usable capacity: **25L net**
 Rated electrical power: **1.45kW**
 Power supply required: **13A**

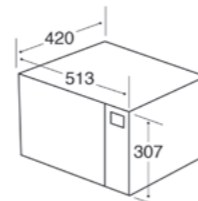

Stainless steel



Black

VM131

Built-in microwave oven

Features

- Microwave function
- Auto defrost
- Quick start
- LED timer and clock
- 5 microwave power levels - 900W max.
- Interior lateral light
- Acoustic end of programme signal
- Left-hand hinged door
- Safety key lock

Accessories

- Glass turntable - 315mm diameter
- Turntable ring

Available in stainless steel, black

Technical specification

Total usable capacity: **25L net**
 Rated electrical power: **1.45kW**
 Power supply required: **13A**

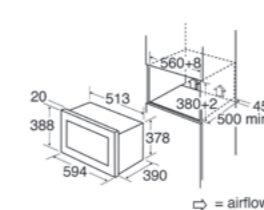

Stainless steel



Black

VM231

Built-in microwave oven and grill

Features

- Microwave function
- Grill function
- Microwave/grill function
- Auto defrost
- Quick start
- LED timer and clock
- 5 microwave power levels - 900W max.
- Grill rating - 1kW
- Interior lateral light
- Acoustic end of programme signal
- Left-hand hinged door
- Safety key lock

Accessories

- Glass turntable - 315mm diameter
- Turntable ring
- Trivet

Available in stainless steel, black

Technical specification

Total usable capacity: **25L net**
 Rated electrical power: **1.45kW**
 Power supply required: **13A**

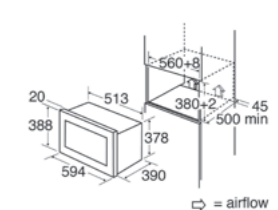

Microwaves



VM452

Built-in microwave oven, grill and convection oven

Features

- Microwave function
- Grill function
- Convection oven function
- Microwave/grill function
- Microwave/convection oven function
- Grill/convection function
- Combination cooking function
- Auto defrost
- 10 auto cook programmes
- Quick start
- LED timer and clock
- 5 microwave power levels - 900W max.
- Grill rating 1.1kW
- Convection oven rating - 2.5kW (max. temperature on convection programme is 220°C)
- Interior lateral light
- Acoustic end of programme signal
- Left-hand hinged door
- Safety key lock

Accessories

- Glass turntable - 315mm diameter
- Turntable ring
- Trivet

Available in stainless steel

Technical specification

Total usable capacity: **25L net**
 Rated electrical power: **2.5kW**
 Power supply required: **13A**

Fitting note: This microwave oven has a convection oven function but is not intended to be used as a substitute for a standard oven. Not suitable for built-under worktop fitting.

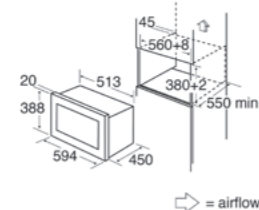

⇒ = airflow



VM551

Wall unit microwave oven

Features

- Microwave function
- Manual defrost
- Auto defrost
- 8 auto cook programmes
- Quick start
- LED timer and clock
- 5 microwave power levels - 700W max.
- Interior light
- Acoustic end of programme signal
- Left-hand hinged door
- Safety key lock

Accessories

- Glass turntable - 245mm diameter
- Turntable ring

Available in stainless steel

Technical specification

Total usable capacity: **17L net**
 Rated electrical power: **1.05kW**
 Power supply required: **5A**

Fitting note: Not suitable for built-under worktop fitting.

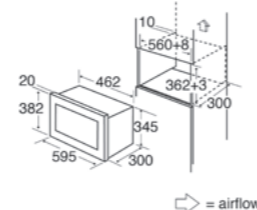

⇒ = airflow

Compact appliances



VK703

Compact steam oven and grill

Features

- Full touch control
- LED display
- Interior lateral halogen light
- Stainless steel interior
- Variable temperature
- Variable grill
- Removable 1L water reservoir
- 8 auto cook programmes
- Programmable clock/timer
- Double glazed removable door with removable inner door glass for easy cleaning
- Safety key lock

Accessories

- Stainless steel steam cooking set
- Trivet
- Wire shelf

Available in stainless steel

Technical specification

Total usable capacity: **32L net**
 Rated electrical power: **1.3kW**
 Power supply required: **13A**

Fitting note: Should be installed as a built-in appliance.

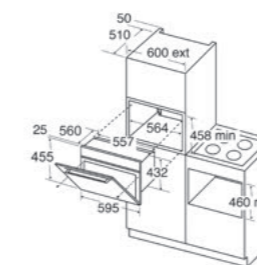

Black

VK903

Compact combination microwave, grill and fan oven

Features

- Full touch control
- LED display
- 6 microwave power levels - 900W max.
- Interior light
- Auto defrost
- 3 auto programmes
- Programmable clock/timer
- Cooling fan
- Double glazed removable door
- Safety key lock
- Acoustic end of programme signal

Accessories

- Wire shelf
- Glass turntable - 360mm diameter
- Turntable ring
- Trivet and grill pan

Available in stainless steel, black

Technical specification

Total usable capacity: **40L net**
 Rated electrical power: **3.1kW**
 Power supply required: **13A**

Fitting note: Should be installed as a built-in appliance.

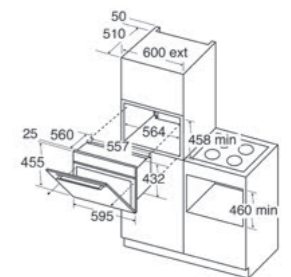

Compact appliances



Black

VC820

Fully automatic coffee maker

Features

- Fully automatic
- Full touch control
- Electronic programmer with LCD display
- 5 coffee strength settings
- Steam nozzle
- One or two cups
- Procino - automatic latte and cappuccino
- 5 cup sizes
- 3 temperature settings
- Compatible with ground coffee and coffee beans
- Hot water and steam
- Integral water tank: 1.8L
- Integral coffee container: 0.2kg
- Low coffee warning
- Low water warning
- Removable drip tray
- Adjustable grind setting
- Integrated coffee grinder

Available in stainless steel, black

Technical specification

Rated electrical power: **1.35kW**
 Power supply required: **13A**
 Pump pressure: **15Bar**

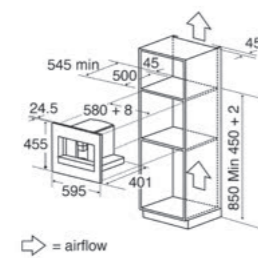

Drawers



VW143

Warming drawer

Features

- Fan heat
- Temperature adjustable from 40°C to 80°C
- 6 place settings
- Smooth runners
- Power indicator light

Available in stainless steel

Technical specification

Rated electrical power: **440W max.**
 Power supply required: **3A**
 Maximum capacity: **20kg**

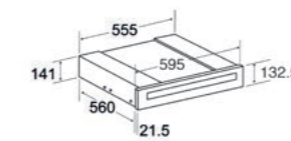

Stainless steel



Black

VW153

Push-push warming drawer

Features

- Fan heat
- Temperature adjustable from 40°C to 80°C
- 6 place settings
- Smooth runners
- Power indicator light
- Push-push opening

Available in stainless steel, black

Technical specification

Rated electrical power: **0.44kW max.**
 Power supply required: **3A**
 Maximum capacity: **20kg**

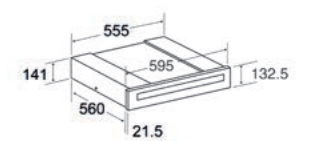

5
YEARS
PARTS
2 YEARS LABOUR



Double ovens

Double ovens

Available in both built-in and built-under options, our A-rated double ovens offer a winning combination of extra cooking space and outstanding features.

Generous capacity

Choose between the **DC740** and **DC940** for useful extra cooking space at either an under-counter or eye-level height with built-under and built-in options. Design your cooking space around you.

well as a defrost mode and warming function to give you total control over your cooking. There is easy clean enamel inside that will make removing any cooking residue a breeze and anti-tilt shelving as standard to ensure that you can add and remove heavy pans and trays safely.

More space

Maximise your cooking space with a built-in or built-under double oven. With flexible cooking functions in both the top and bottom ovens you can grill, bake, warm and roast however you need to. Prepare all your dishes simultaneously and make your practical double oven work for you so that more precious family time can be spent together at the table.

Choose your style

For eye level cooking choose the DC941 with 2 spacious oven cavities that can be installed in a wall unit for easy access to every shelf. If you prefer a more traditional under counter layout, the DC741 is designed to be installed below the worktop for an uninterrupted line throughout your kitchen.

Flexible cooking

Each model comes with a grill, both conventional and speedy fan oven settings as

Available in both black and with stainless steel options, the DC741 and DC941 feature our new style ergonomic control knobs, touch control timers and streamlined handle detailing to finish off your kitchen perfectly.

Quick guide to double ovens

Choose from either a built-in double oven for eye-level cooking, or a built-under model that fits beneath your worktop and makes the most of your low level space.

Both our double ovens are A-rated in both oven cavities.

Built-under double ovens



DC741

- **Built-under electric double oven**
 - 4/3 functions
 - Touch control programmer
 - Available in stainless steel, and black
- Details on [p33](#)

Built-under double ovens



- Top oven
- ☀️
 - 📅
 - 🔥
 - 🍷
- Main oven
- ☀️
 - ✖️
 - ⊗



- Top oven
- ☀️
 - 📅
 - 🔥
 - 🍷
- Main oven
- ☀️
 - ✖️
 - ⊗

Built-in double ovens



DC941

- **Built-in electric double oven**
 - 4/3 functions
 - Touch control programmer
 - Available in stainless steel and black
- Details on [p33](#)

DC741

Built-under electric double oven

Features

- Touch control programmable electronic clock/timer
- Easy clean enamel interior
- Interior halogen lights
- Cooling fan
- Chromed rack sides with integrated anti-tilt shelves
- Double glazed removable doors with removable inner glass for easy cleaning
- Grill pan with grid
- 3 flat oven shelves

Accessories

- Grill pan with grid
- 3 flat oven shelves

Available in stainless steel, black

Technical specification

Top oven usable capacity: **35L net**
 Main oven usable capacity: **50L net**
 Rated electrical power: **4.3kW**
 Power supply required: **20A**

Fitting Notes

Please ensure you check that there is sufficient clearance above built-under ovens when fitting the relevant hob.

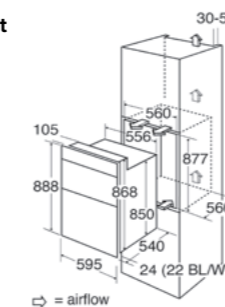

DC941

Built-in electric double oven

Features

- Touch control programmable electronic clock/timer
- Easy clean enamel interior
- Interior halogen lights
- Cooling fan
- Chromed rack sides with integrated anti-tilt shelves
- Double glazed removable doors with removable inner glass for easy cleaning
- Grill pan with grid
- 3 flat oven shelves

Accessories

- Grill pan with grid
- 3 flat oven shelves

Available in stainless steel, black

Technical specification

Top oven usable capacity: **35L net**
 Main oven usable capacity: **59L net**
 Rated electrical power: **4.3kW**
 Power supply required: **20A**

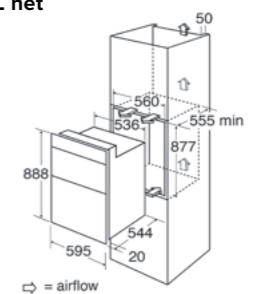

5
YEARS
PARTS

2 YEARS LABOUR



Hobs

Everyone has their preference, and we offer everything from bridging induction hobs to professional-style gas hobs in sizes from domino to extra wide.

Gas hobs

From practical four burner models to huge six burner hobs, we cater for every type of cook. Wok burners give you maximum power when you need it and additional wok supports to allow you to get creative with your cooking.

If choosing this option, ensure you use compatible ferromagnetic pans. High quality, flat-based pans work best with induction hobs, and new pans will carry a symbol on the packaging to show they are compatible.

Schott Ceran glass

Some CDA hobs feature Schott Ceran® glass, an extremely stable material that is resistant against abrupt temperature changes, making it capable of withstanding the daily wear and tear of a frequently-used kitchen.

Ceramic hobs

Our ceramic hob range is a practical option for those wanting an easy-to-clean cooking area. The resistant ceramic glass material is ideal for households where a quick wipe over after cooking is all you have time for.

The four-millimetre-thick glass is extremely heat-permeable, and is able to transfer heat quickly and efficiently so that it is transmitted directly to the pots and pans, keeping the rest of the hob relatively cool. This makes it both safe and energy efficient. Glass-ceramic is the only material suitable for all kinds of heating technologies - ceramic, induction and gas.

Induction hobs

Induction hobs reach temperature quickly and reduce the energy losses associated with heat escaping. Choose induction for quicker cooking, an easy-to-clean hob surface and precision control.

Quick guide to gas hobs

Our range of gas hobs offers a wide choice. This comprehensive collection includes 1 and 2 burner domino hobs, functional 4 burner hobs and stunning 5 and 6 burner hobs for the most professional kitchen.

We have included beautiful, solid cast iron pan supports as standard with most of our hobs, whilst the **HCG301**, **HG6150** and **HG6250** have enamelled pan supports if you prefer a dishwasher-friendly option.

Gas hobs



HCG302

- 2 burners
 - Enamel pan support
 - Front control
- Details on [p41](#)



HG6151

- 4 burners
 - Enamel pan supports
 - Side control
- Details on [p41](#)



HG6251

- 4 burners
 - Enamel pan support
 - Front control
 - Wok burner
 - Stainless steel or black
- Details on [p42](#)



HG6351

- 4 burners
 - Cast iron pan support
 - Front control
 - Wok burner
- Details on [p42](#)



HG7251

- 5 burners
 - Cast iron pan support
 - Front control
 - Wok burner
- Details on [p43](#)



HG7351

- 5 burners
 - Cast iron pan support
 - Front control
 - Wok burner
- Details on [p43](#)



HG7501

- 4 burners
 - Cast iron pan supports
 - Front control
 - 2 wok burners (1 dual control)
- Details on [p44](#)



HG9351

- 5 burners
 - Cast iron pan supports
 - Front control
 - Wok burner
- Details on [p44](#)



HG6251

- 6 burners
 - Cast iron pan supports
 - Wok control
 - Side control
- Details on [p45](#)

Gas-on-glass hobs



HG3610

- Single burner gas-on-glass
 - Cast iron pan supports
 - Front control
 - Wok burner
- Details on [p46](#)

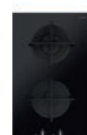

HG3620

- 2 burner gas-on-glass
 - Cast iron pan supports
 - Front control
- Details on [p46](#)

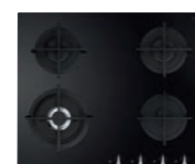

HVG671

- 4 burner gas-on-glass
 - Cast iron pan supports
 - Front control
 - Wok burner
- Details on [p47](#)



HVG781

- 5 burner gas-on-glass
 - Cast iron pan supports
 - Front control
 - Wok burner
- Details on [p47](#)

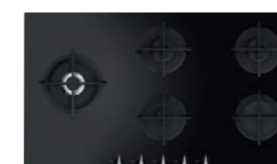

HVG971

- 5 burner gas-on-glass
 - Cast iron pan supports
 - Front control
 - Wok burner
- Details on [p49](#)



HVG621

- 4 burner gas-on-glass
 - Cast iron pan supports
 - Front control
 - Stainless steel or black
- Details on [p48](#)



HVG721

- 5 burner gas-on-glass
 - Cast iron pan supports
 - Front control
 - Wok burner
 - Stainless steel or black
- Details on [p48](#)

Flame Safe

All CDA gas hobs have automatic ignition and a flame failure safety device 'Flame Safe' as standard.

Flame Safe is a feature designed to close off the gas supply in the event that a burner is accidentally extinguished.

Quick guide to electric hobs

Our range of electric hobs includes a comprehensive selection of both manual and touch control 2, 4 and 5 zone ceramic hobs, high-tech induction hobs and domino hobs which you can put together in different combinations to suit your requirements.

All CDA ceramic and induction hobs have easy clean surfaces, shatterproof ceramic safety glass and residual heat indicators.

Electric



HE3141

- 2-plate electric domino hob
- Front rotary control
- Details on [p51](#)



HE6052

- 4-plate electric hob
- Side rotary control
- Details on [p52](#)

Ceramic



HC3621

- 2 zone ceramic domino hob
- Front touch control
- Details on [p53](#)

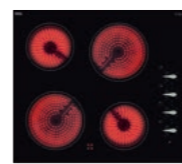

HC6212

- 4 zone ceramic hob
- Side rotary control
- Details on [p53](#)

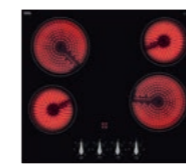

HC6312

- 4 zone ceramic hob
- Front rotary control
- Details on [p54](#)

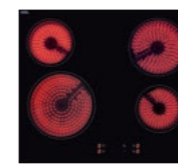

HC6621

- 4 zone ceramic hob
- Front rotary control
- Details on [p54](#)

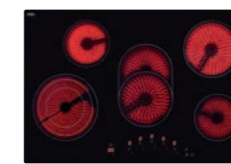

HC7621

- 5 zone ceramic hob
- Front rotary control
- Details on [p55](#)

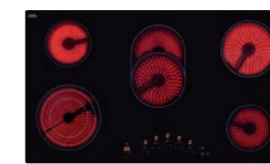

HC9621

- 5 zone ceramic hob
- Front rotary control
- Details on [p55](#)

Ceramic

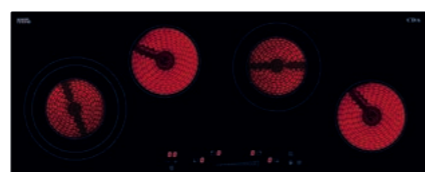

HC9606

- 4 zone ceramic hob
- Front touch control
- Details on [pX6](#)

Induction



HN3621

- 2 zone domino
- Induction hob
- Front touch control
- Details on [p57](#)



HN6111

- 4 zone induction hob
- Front touch control
- Details on [p57](#)



HN6411

- 4 zone induction hob
- Front touch control
- Power management
- Details on [p58](#)



HN6732

- 4 zone induction hob
- Front touch control
- Bridging function
- Details on [p58](#)

Induction



HN6841

- 4 zone induction hob
- Front touch control
- Bridging function
- Illuminated front edge
- Details on [p59](#)

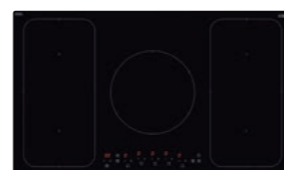

HN9611

- 5 zone induction hob
- Front touch control
- Bridging function
- Details on [p60](#)



HN9626

- 4 zone linear induction hob
- Front touch control
- Details on [p60](#)

Indu-Air



HNE8

- 4 zone induction hob
- Front touch control
- Bridging function
- Details on [p61](#)



Gas hobs

Our range includes a variety of sizes and styles to suit every kitchen, whether you're a casual cook or a dedicated dinner party chef.

Gas hobs



HCG302

Domino two burner gas hob



Features

- Front control
- Enamel pan support
- Automatic ignition
- Flame failure safety device

Accessories

- LPG conversion kit included

Optional accessories

- Domino joint strip, AHJ30

Available in stainless steel

Burners technical specification:

Front, semi-rapid: **1.75kW**
 Rear, rapid: **3kW**
 Rated gas input: **4.75kW**
 Rated electrical power: **1W**
 Power supply required: **3A**

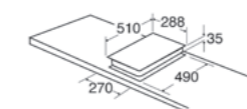

HG6151

Four burner gas hob



Features

- Side control
- Enamel pan supports
- Automatic ignition
- Flame failure safety device

Accessories

- LPG conversion kit included

Available in stainless steel

Burners technical specification

Front left, rapid: **3kW**
 Front right, auxiliary: **1kW**
 Rear left, semi-rapid: **1.75kW**
 Rear right, semi-rapid: **1.75kW**
 Rated gas input: **7.5kW**
 Rated electrical power: **1W**
 Power supply required: **3A**

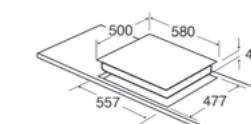

Gas hobs



Stainless steel



Black

HG6251

Four burner gas hob



Features

- Front control
- Enamel pan supports
- Automatic ignition
- Flame failure safety device
- Wok burner

Accessories

- LPG conversion kit included

Available in stainless steel, black

Burners technical specification

Front left, triple ring/wok: **3.8kW**
 Front right, auxiliary: **1kW**
 Rear left, semi-rapid: **1.75kW**
 Rear right, semi-rapid: **1.75kW**
 Rated gas input: **8.3kW**
 Rated electrical power: **1W**
 Power supply required: **3A**

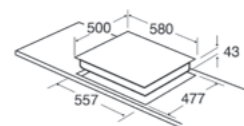

HG6351

Four burner gas hob



Features

- Front control
- Cast iron pan supports
- Automatic ignition
- Flame failure safety device
- Wok burner

Accessories

- Wok support
- LPG conversion kit included

Available in stainless steel; LPG gas version, HG6350LSS

Burners technical specification

Front left, triple ring/wok: **3.8kW**
 Front right, auxiliary: **1kW**
 Rear left, semi-rapid: **1.75kW**
 Rear right, semi-rapid: **1.75kW**
 Rated gas input: **8.3kW**
 Rated electrical power: **1.1W**
 Power supply required: **3A**

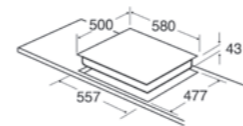

HG7251

Five burner gas hob



Features

- Front control
- Cast iron pan supports
- Automatic ignition
- Flame failure safety device
- Wok burner

Accessories

- Wok support
- LPG conversion kit included

Available in black

Burners technical specification

Front left, semi-rapid: **1.75kW**
 Front right, auxiliary: **1kW**
 Centre, triple ring/wok: **3.8kW**
 Rear left, semi-rapid: **1.75kW**
 Rear right, rapid: **3kW**
 Rated gas input: **11.3kW**
 Rated electrical power: **2W**
 Power supply required: **3A**

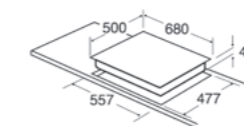

HG7351

Five burner gas hob



Features

- Front control
- Cast iron pan supports
- Automatic ignition
- Flame failure safety device
- Wok burner

Accessories

- Wok support
- LPG conversion kit included

Available in stainless steel

Burners technical specification

Front left, semi-rapid: **1.75kW**
 Front right, auxiliary: **1kW**
 Centre, triple ring/wok: **3.8kW**
 Rear left, semi-rapid: **1.75kW**
 Rear right, rapid: **3kW**
 Rated gas input: **11.3kW**
 Rated electrical power: **2W**
 Power supply required: **3A**

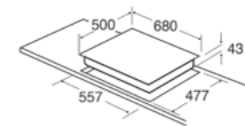

Gas hobs



HG7501

Four burner gas hob



Features

- Front control
- Cast iron pan supports
- Automatic ignition
- Flame failure safety device
- 2 wok burners (1 dual control)

Accessories

- Wok support (not shown)
- LPG conversion kit included

Available in stainless steel

Burners technical specification

Rear central, semi-rapid: **1.75kW**
 Right, triple ring/wok: **3.5kW**
 Front central, auxiliary: **1kW**
 Left, dual burner: **4.2kW**
 Rated gas input: **10.45kW**
 Rated electrical power: **1W**
 Power supply required: **3A**

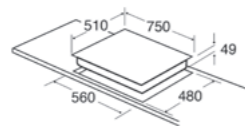

HG9351

Five burner gas hob



Features

- Front control
- Cast iron pan supports
- Automatic ignition
- Flame failure safety device
- Wok burner

Accessories

- Wok support
- LPG conversion kit included

Available in stainless steel

Burners technical specification

Front central, auxiliary: **1kW**
 Front right, semi-rapid burner: **1.75kW**
 Left, wok burner: **3.8kW**
 Rear centre, rapid: **3kW**
 Rear right, semi-rapid: **1.75kW**
 Rated gas input: **11.3kW**
 Rated electrical power: **2W**
 Power supply required: **3A**

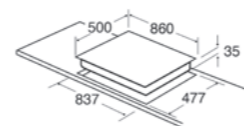

HG9321

Six burner gas hob



Features

- Side control
- Cast iron pan supports
- Automatic ignition
- Flame failure safety device
- Wok burner

Accessories

- Wok support
- LPG conversion kit included

Available in stainless steel

Burners technical specification

Front left, triple ring/wok: **3.5kW**
 Front centre, auxiliary: **1kW**
 Front right, auxiliary: **1kW**
 Rear left, semi-rapid: **1.75kW**
 Rear centre, rapid: **3kW**
 Rear right, semi-rapid: **1.75kW**
 Rated gas input: **12kW**
 Rated electrical power: **1.1W**
 Power supply required: **3A**

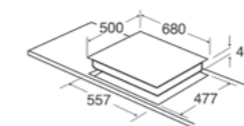

Gas-on-glass hobs



HG3610

Domino single burner gas-on-glass hob

Features

- Front control
- Cast iron pan supports
- Automatic ignition
- Flame failure safety device
- Wok burner

Accessories

- Wok support (not shown)
- LPG conversion kit included

Available in black

Burners technical specification

Centre, triple ring/wok: **3.5kW**
 Rated gas input: **3.5kW**
 Rated electrical power: **1W**
 Power supply required: **3A**

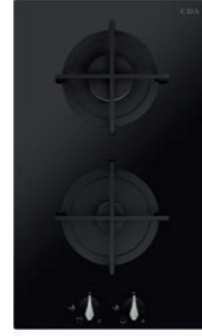
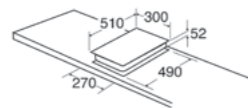

HG3620

Domino two burner gas-on-glass hob

Features

- Front control
- Cast iron pan supports
- Automatic ignition
- Flame failure safety device

Accessories

- LPG conversion kit included

Available in black

Burners technical specification

Front, rapid: **3kW**
 Rear, semi-rapid: **1.75kW**
 Rated gas input: **4.75kW**
 Rated electrical power: **1W**
 Power supply required: **3A**

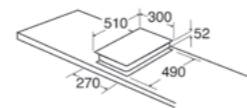

HVG621

Four burner gas-on-glass hob

Features

- Front control
- Cast iron pan supports
- Automatic ignition
- Flame failure safety device
- Bevelled edges

Accessories

- LPG conversion kit included

Available in black

Burners technical specification

Front left, rapid: **3kW**
 Front right, auxiliary: **1kW**
 Rear left, semi-rapid: **1.75kW**
 Rear right, semi-rapid: **1.75kW**
 Rated gas input: **7.5kW**
 Rated electrical power: **1.1W**
 Power supply required: **3A**

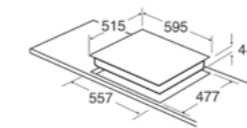

HVG721

Five burner gas-on-glass hob

Features

- Front control
- Cast iron pan supports
- Automatic ignition
- Flame failure safety device
- Bevelled edges
- Wok burner

Accessories

- Wok support (not shown)
- LPG conversion kit included

Available in black

Burners technical specification

Front left, auxiliary: **1kW**
 Front right, semi-rapid: **1.75kW**
 Centre, wok: **3.8kW**
 Rear left, rapid: **3kW**
 Rear right, semi-rapid: **1.75kW**
 Rated gas input: **11.3kW**
 Rated electrical power: **1.1W**
 Power supply required: **3A**

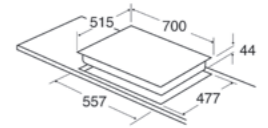

Gas-on-glass hobs



HVG671

Four burner gas-on-glass hob

Features

- Front control
- Cast iron pan supports
- Automatic ignition
- Flame failure safety device

Accessories

- Wok support (not shown)
- LPG conversion kit included

Available in black

Burners technical specification

Front left, triple ring/wok: **3.5kW**
 Front right, auxiliary: **1kW**
 rear left, rapid: **3kW**
 Rear right, semi-rapid: **1.75kW**
 Rated gas input: **8kW**
 Rated electrical power: **1W**
 Power supply required: **3A**

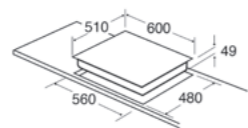

Gas-on-glass hobs



HVG781

Five burner gas-on-glass hob

Features

- Front control
- Cast iron pan supports
- Automatic ignition
- Flame failure safety device
- Wok burner

Accessories

- Wok support (not shown)
- LPG conversion kit included

Available in black

Burners technical specification

Front left, rapid: **3kW**
 Front right, auxiliary: **1kW**
 Centre, wok: **3.5kW**
 Rear left, rapid: **3kW**
 Rear right, semi-rapid: **1.75kW**
 Rated gas input: **11.3kW**
 Rated electrical power: **1W**
 Power supply required: **3A**

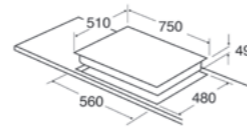

HVG971

Five burner gas-on-glass hob

Features

- Front control
- Cast iron pan supports
- Automatic ignition
- Flame failure safety device
- Wok burner

Accessories

- Wok support (not shown)
- LPG conversion kit included

Available in black

Burners technical specification

Front right, rapid: **3kW**
 Front centre, auxiliary: **1kW**
 Left, triple ring/wok: **3.8kW**
 Rear centre, semi-rapid: **1.75kW**
 Rear right, semi-rapid: **1.75kW**
 Rated gas input: **11.3kW**
 Rated electrical power: **1W**
 Power supply required: **3A**

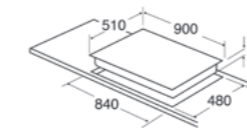



Electric hobs

With something for everyone, our electric hob range includes domino hobs for flexibility, ceramic hobs for easy cleaning and induction hobs for fast, efficient cooking.

Electric hob



HE3141

Domino two plate electric hob

Features

- Front control
- 6 power levels with indicator light
- 1 rapid plates

Available in stainless steel

Hob zones technical specification

Front, 145mm: **1kW**
 Rear, 180mm rapid: **2kW**
 Rated electrical power: **3kW**
 Power supply required: **14A**

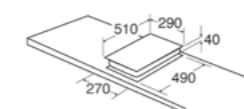

Electric hobs



HE6052

Four plate electric hob

Features

- Side control
- 6 power levels with indicator light
- 2 rapid plates

Available in stainless steel

Hob plates technical specification

Front left, 180mm rapid: **2kW**

Front right, 145mm: **1kW**

Rear left, 145mm rapid: **1.5kW**

Rear right, 180mm rapid: **1.5kW**

Rated electrical power: **6kW**

Power supply required: **30A**

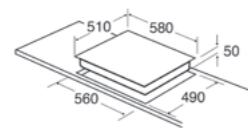

Ceramic hobs

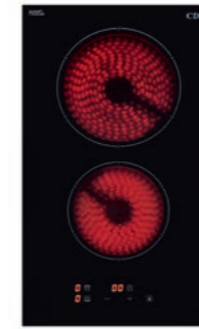

HC3621

Domino two zone ceramic hob

Features

- Front control
- Electronic touch control
- LED display
- 9 power levels
- 99 minute timer
- Safety key lock
- Residual heat indicators
- Easy clean surface
- Ceramic shatterproof safety glass
- Overflow detection
- Overheat detection
- Auto safety switch o
- Time limit security system
- Temperature limiter

Available in black

Hob zones technical specification

Front, 145mm: **1.2kW**

Rear, 180mm: **1.8kW**

Rated electrical power: **3kW**

Power supply required: **13A**

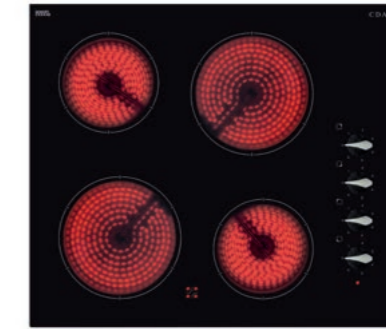
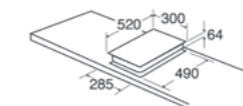

HC6212

Four zone ceramic hob

Features

- Side control
- 6 power levels with indicator light
- Residual heat indicators
- Easy clean surface
- Ceramic shatterproof safety glass
- Temperature limiter

Available in black

Hob zones technical specification

Front left, 180mm: **1.8kW**

Front right, 145mm: **1.2kW**

Rear left, 145mm: **1.2kW**

Rear right, 180mm: **1.8kW**

Rated electrical power: **6kW**

Power supply required: **30A**

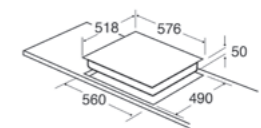

Ceramic hobs

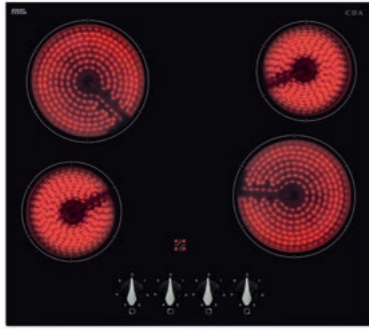

HC6312

Four zone ceramic hob

Features

- Front control
- 6 power levels with indicator light
- Residual heat indicators
- Easy clean surface
- Ceramic shatterproof safety glass
- Temperature limiter

Available in black

Hob zones technical specification

Front left, 145mm: **1.2kW**
 Front right, 180mm: **1.8kW**
 Rear left, 180mm: **1.8kW**
 Rear right, 145mm: **1.2kW**
 Rated electrical power: **6kW**
 Power supply required: **30A**

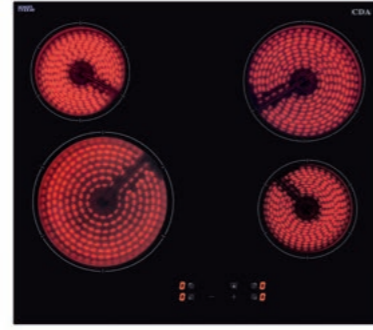
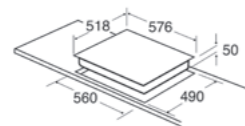

HC6621

Four zone ceramic hob

Features

- Front control
- Electronic touch control
- LED display
- 9 power levels
- Safety key lock
- Residual heat indicators
- Easy clean surface
- Ceramic shatterproof safety glass
- Overflow detection
- Overheat detection
- Auto safety switch o
- Time limit security system
- Temperature limiter

Available in black

Hob zones technical specification

Front left, 210mm: **2.3kW**
 Front right, 145mm: **1.2kW**
 Rear left, 145mm: **1.2kW**
 Rear right, 180mm: **1.8kW**
 Rated electrical power: **6.5kW**
 Power supply required: **30A**

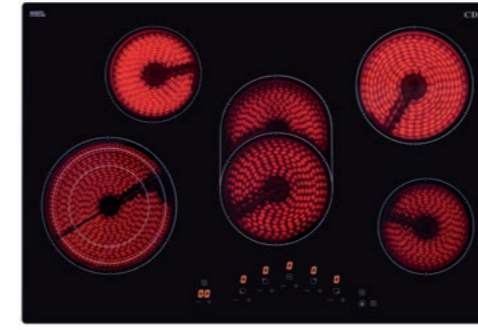
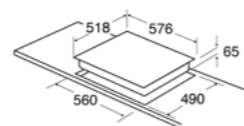

HC7621

Five zone ceramic hob

Features

- Front control
- Electronic touch control
- LED display
- 9 power levels
- 99 minute timer
- Safety key lock
- Residual heat indicators
- Easy clean surface
- Ceramic shatterproof safety glass
- Overflow detection
- Overheat detection
- Auto safety switch o
- Time limit security system
- Temperature limiter

Available in black

Hob zones technical specification

Front left (triple), 120mm: **0.8kW**; 175mm: **1.6kW**;
 210mm: **2.3kW**
 Front right, 145mm: **1.2kW**
 Centre (dual), 170mm: **1.5kW**; 256mm: **2.2kW**
 Rear left, 145mm: **1.2kW**
 Rear right, 180mm: **1.8kW**
 Rated electrical power: **8.7kW**
 Power supply required: **40A**

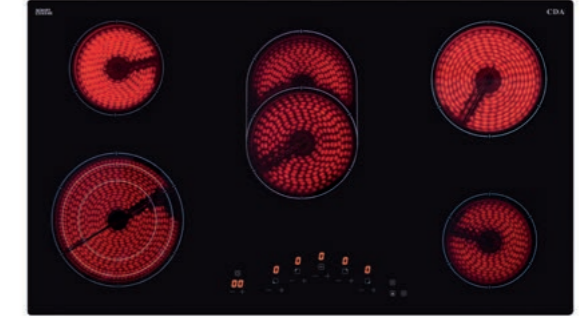
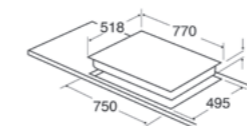

HC9621

Five zone ceramic hob

Features

- Front control
- Electronic touch control
- LED display
- 9 power levels
- 99 minute timer
- Safety key lock
- Residual heat indicators
- Easy clean surface
- Ceramic shatterproof safety glass
- Overflow detection
- Overheat detection
- Auto safety switch o
- Time limit security system
- Temperature limiter

Available in black

Hob zones technical specification

Front left (triple), 120mm: **0.8kW**; 175mm: **1.6kW**;
 210mm: **2.3kW**
 Front right, 145mm: **1.2kW**
 Centre (dual), 170mm: **1.5kW**; 256mm: **2.2kW**
 Rear left, 145mm: **1.2kW**
 Rear right, 180mm: **1.8kW**
 Rated electrical power: **8.7kW**
 Power supply required: **40A**

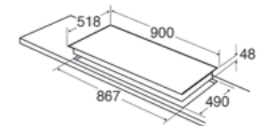

Ceramic hobs

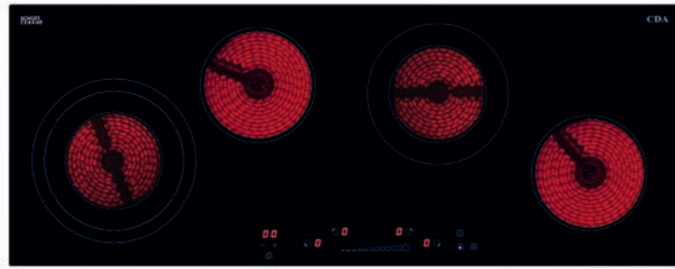

HC9606

Four zone ceramic linear hob

Features

- Front control
- Electronic touch control
- LED display
- 9 power levels
- 99 minute timer
- Safety key lock
- Residual heat indicators
- Easy clean surface
- Ceramic shatterproof safety glass
- Overflow detection
- Overheat detection
- Auto safety switch o
- Time limit security system
- Temperature limiter

Available in black

Hob zones technical specification

Front left (triple), 120mm: **0.8kW**; 175mm: **1.6kW**;
210mm: **2.3kW**
Centre left, 145mm: **1.2kW**
Centre right (dual), 120mm: **0.7kW**; 180mm: **1.7kW**
Front right, 145mm: **1.2kW**
Rated electrical power: **6.4kW**
Power supply required: **30A**

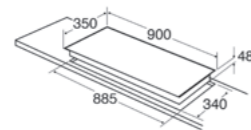

Induction hobs



HN3621

Domino two zone induction hob

Features

- Front control
- Electronic touch control
- LED display
- 9 power levels
- 99 minute timer
- Safety key lock
- Residual heat indicators
- Keep warm function
- Easy clean surface
- Ceramic shatterproof safety glass
- Overflow detection
- Overheat detection
- Automatic pan detection
- Small object detection
- Auto safety switch o
- Time limit security system
- Temperature limiter

Available in black

Hob zones technical specification

Front, 160mm: **1.4kW**
Rear, 160mm: **1.4kW**
Rated electrical power: **2.8kW**
Power supply required: **13A**

Fitting note

Please ensure that you check that there is sufficient clearance when fitting induction hobs over both single and built-under double ovens and that adequate ventilation is provided.

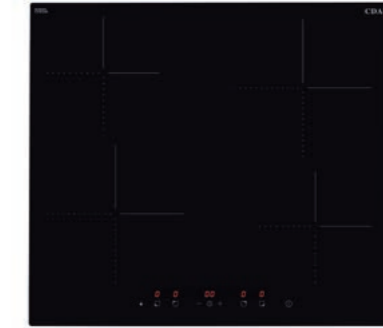
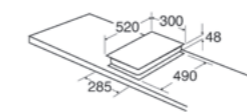

HN6111

Four zone induction hob

Features

- Front control
- Electronic touch control
- LED display
- 9 power levels
- Booster function on all zones
- 99 minute timer
- Safety key lock
- Residual heat indicators
- Keep warm function
- Easy clean surface
- Ceramic shatterproof safety glass
- Overflow detection
- Overheat detection
- Automatic pan detection
- Small object detection
- Auto safety switch o
- Time limit security system
- Temperature limiter

Available in black

Hob zones technical specification

Front left, 210mm: **2kW**; with booster, **3kW**
Front right, 160mm: **1.2kW**; with booster, **1.4kW**
Rear left, 160mm: **1.2kW**; with booster, **1.4kW**
Rear right, 210mm: **2kW**; with booster, **3kW**
Rated electrical power: **7.4kW**
Power supply required: **32A**

Fitting note

Please ensure that you check that there is sufficient clearance when fitting induction hobs over both single and built-under double ovens and that adequate ventilation is provided.

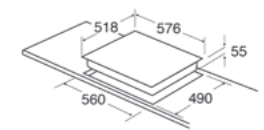

Induction hobs

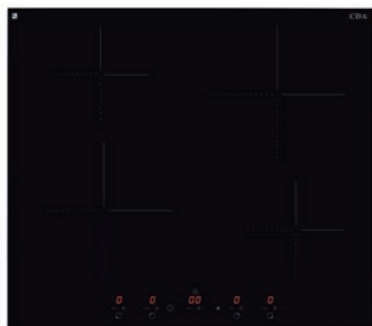

HN6411

Four zone configurable induction hob

Features

- Front control
- Electronic touch control
- LED display
- 9 power levels
- Booster function on all zones
- 99 minute timer
- Safety key lock
- Residual heat indicators
- Power management system
- Easy clean surface
- Ceramic shatterproof safety glass
- Overflow detection
- Overheat detection
- Automatic pan detection
- Small object detection
- Auto safety switch o
- Time limit security system
- Temperature limiter

Available in black

Hob zones technical specification

Front left, 210mm: **2kW**; with booster, **2.8kW**
 Front right, 160mm: **1.2kW**; with booster, **1.4kW**
 Rear left, 160mm: **1.2kW**; with booster, **1.4kW**
 Rear right, 210mm: **2kW**; with booster, **2.8kW**
 Rated electrical power: **2.8/3.7/6/7.4kW** (configurable)
 Power supply required: **13-32A** (configurable)
 If the hob is configured for use with a supply below 32A, the hob will automatically regulate the power consumption so as not to exceed the power available.

Fitting note

Please ensure that you check that there is sufficient clearance when fitting induction hobs over both single and built-under double ovens and that adequate ventilation is provided.

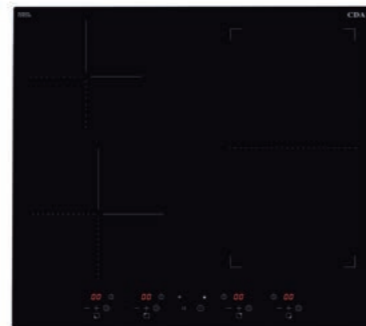
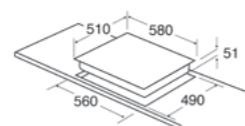

HN6732

Four zone configurable induction hob

Features

- Front control
- Electronic touch
- LED display
- 9 power levels
- Booster function on all zones
- 99 minute timer
- Safety key lock
- Residual heat indicators
- Power management system
- Pause/restart function
- Keep warm function
- Right zones bridging function
- Easy clean surface
- Ceramic shatterproof safety glass
- Overflow detection
- Overheat detection
- Automatic pan detection
- Small object detection
- Time limit security system
- Temperature limiter

Available in black

Hob zones technical specification

Front left, 210mm: **2kW**; with booster, **2.8kW**
 Front right, 180mm: **1.5kW**; with booster, **2.5kW**
 Rear left: 160mm, **1.2kW**; with booster, **1.4kW**
 Rear right: 180mm, **1.5kW**; with booster, **2.5kW**
 Rated electrical power: **2.8/3.7/6/7.4kW** (configurable)
 Power supply required: **13-32A** (configurable)
 If the hob is configured for use with a supply below 32A, the hob will automatically regulate the power consumption so as not to exceed the power available.

Fitting note

Please ensure that you check that there is sufficient clearance when fitting induction hobs over both single and built-under double ovens and that adequate ventilation is provided.

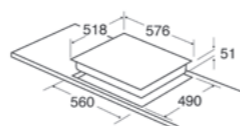

HN6841

Four zone induction hob with illuminated front edge

Features

- Front control
- Electronic touch and slide control
- LED display
- 9 power levels
- Booster function on all zones
- 99 minute timer
- Safety key lock
- Residual heat indicators
- Illuminated front edge
- Pause/restart function
- Keep warm function
- Melt function
- Simmer function
- Left zones can be bridged
- Right zones can be bridged
- Side bevelled edges
- Easy clean surface
- Ceramic shatterproof safety glass
- Overflow detection
- Overheat detection
- Automatic pan detection
- Small object detection
- Auto safety switch o

Available in black

Hob zones technical specification

Front left, 220mm x 190mm: **2.2kW**; with booster, **3.7kW**
 Front right, 220 x 190mm, **2.2kW**; with booster, **3.7kW**
 Rear left: 220mm x 190mm, **2.2kW**; with booster, **3.7kW**
 Rear right: 220 x 190mm, **2.2kW**; with booster, **3.7kW**
 Rated electrical power: **7.4kW**
 Power supply required: **32A**

Fitting note

Please ensure that you check that there is sufficient clearance when fitting induction hobs over both single and built-under double ovens and that adequate ventilation is provided.

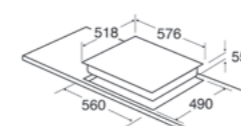



HN9611

Five zone induction hob

Features

- Front control
- Electronic touch
- LED display
- 9 power levels
- Booster function on all zones
- 99 minute timer
- Safety key lock
- Residual heat indicators
- Pause/restart function
- Keep warm function
- Melt function
- Simmer function
- Left zones bridging function
- Right zones bridging function
- Easy clean surface
- Ceramic shatterproof safety glass
- Overflow detection
- Overheat detection
- Automatic pan detection
- Small object detection
- Auto safety switch o
- Time limit security system
- Temperature limiter

Available in black

Hob zones technical specification

Front left, 210mm: **2.1kW**; with booster, **3.7kW**
 Front right, 210mm: **2.1kW**; with booster, **3.7kW**
 Centre: 260mm, **2.6kW**; with booster, **3.7kW**
 Rear left: 210mm, **2.1kW**; with booster, **3.7kW**
 Rear right: 210mm, **2.1kW**; with booster, **3.7kW**
 Rated electrical power: **11.1kW**
 Power supply required: **45A**

Fitting note

Please ensure that you check that there is sufficient clearance when fitting induction hobs over both single and built-under double ovens and that adequate ventilation is provided.

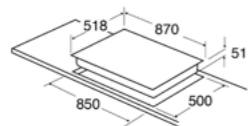

HN9626

Four zone linear induction hob

Features

- Front control
- Electronic touch and slide control
- LED display
- 9 power levels
- Booster function on all zones
- 99 minute timer
- Safety key lock
- Residual heat indicators
- Pause/restart function
- Keep warm function
- Easy clean surface
- Ceramic shatterproof safety glass
- Overflow detection
- Overheat detection
- Automatic pan detection
- Small object detection
- Auto safety switch o

Available in black

Hob zones technical specification

Front left, 220mm: **2.3kW**; with booster, **3kW**
 Centre left, 180mm: **1.2kW**; with booster, **1.4kW**
 Centre right, 180mm: **1.2kW**; with booster, **1.4kW**
 Front right, 220mm: **2.3kW**; with booster, **3kW**
 Rated electrical power: **7.4kW**
 Power supply required: **32A**

Fitting note

Please ensure that you check that there is sufficient clearance when fitting induction hobs over both single and built-under double ovens and that adequate ventilation is provided.

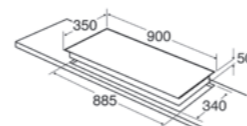

ENERGY
B

HNE8

Indu-Air four zone induction hob with built-in extractor

Features

- Front control
- Electronic touch and slide control
- LED display
- 9 power levels
- Booster function on all zones
- 119 minute timer
- Safety key lock
- Residual heat indicators
- Pause/restart function
- Keep warm function
- Melt function
- Simmer function
- Left zones bridging function
- Right zones bridging function
- Easy clean surface
- Ceramic shatterproof safety glass
- Overflow detection
- Overheat detection
- Automatic pan detection
- Small object detection
- Auto safety switch o
- Time limit security system
- Temperature limiter

Available in black

Hob zones technical specification

Front left, 220mm x 184mm: **2.1kW**; with booster, **3.7kW**
 Front right, 220mm x 184mm: **2.1kW**; with booster, **3.7kW**
 Rear left, 220mm x 184mm: **2.1kW**; with booster, **3.7kW**
 Rear right, 220mm x 184mm: **2.1kW**; with booster, **3.7kW**
 Rated electrical power: **7.4kW**
 Power supply required: **16A x2**

Extractor features

- Ducted/re-circulating installation
- 3 speeds + intensive
- Aluminium grease filters

Extractor optional accessories

- Ducting kit, AED61/63/64
- Charcoal filter for re-circulation, CHA28

Extractor technical specification

- Outlet diameter: **150mm with adaptor**
- Noise level: **67dBA**
- Extraction rate: **457m³/h**
- Rated electrical power: **168W**
- Power supply required: **3A**

Energy efficiency rating: B

Fitting note

This appliance is not suitable for installation above an oven.

Inset installation

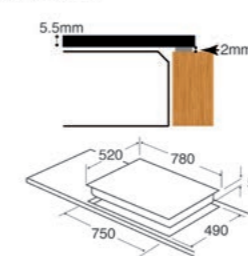

Flush installation

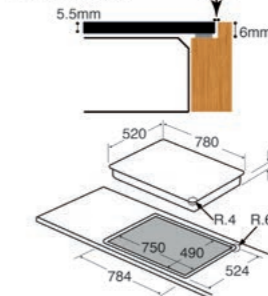

Under counter

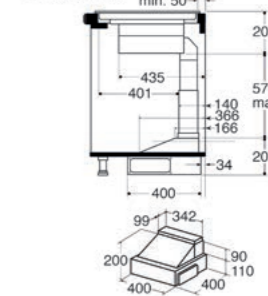

5
YEARS
PARTS

2 YEARS LABOUR



Extractors

As well as keeping your kitchen fresh, a stylish CDA extractor also provides a stunning focal point in the room, adding impact to the overall design.

LED lighting

For ambient lighting in the kitchen, our range of edge-lit extractors give you the option to switch on LED lighting in a range of colours. The **EKP** range are in a curved glass design, while **EKN** models have flat glass. Both come with edge lighting detail.

For clear, ceiling-height extraction and bright LED lighting, take a look at the **EVX90** and **EVS90**. The EVX models come with stunning lighting and great extraction rates. Our EVS have 14 led stars placed into the ceiling hood, has to be seen!

Design

Our range of extractors offer a choice of fitting styles and finishes that will perfectly complement your kitchen. Built using the highest quality steel, glass and aluminium, the extractor collection features sharp lines and elegant curves whilst offering quiet, powerful air filtration in the kitchen.

Choose from discreet ceiling editions that are installed out of view and are controlled remotely, or downdrafts that slip quietly away beneath your work surfaces.

Ducted

Choose between ducting your extractor outside or recirculating filtered, cleaned air back into your kitchen. We provide a comprehensive range of ducting kits and charcoal filters, listed on our accessories pages, to support your preference.

Clean air function

The clean air function turns your extractor on for ten minutes every hour, outside of use during cooking. In these ten minutes the extractor works to purify the air in your kitchen, meaning it is not just a companion for your hob; it even works hard when you're not cooking.

Quick guide to extractors

Our extensive range of extractors includes integrated and under-canopy models, together with a great selection of stylish, contemporary chimney and island extractors. Most CDA extractor models have dishwasher-friendly aluminium grease filters.

Extraction and noise level measurements

The extraction rate and noise level measurements are displayed in accordance with EN61591 for extraction rates and EN60704 for noise levels. These measurements provide an approximation of real-world performance when installed with recommended ducting kits.

Required distance between hob and extractor

Please refer to both your hob and extractor instructions before installation - for legal requirements, the distance between your hob and extractor should be determined by the maximum measurement provided.

Ducting advice

Using ducting of smaller diameter than that recommended may increase the noise level and can reduce the efficiency of your extractor. Where possible, always use the largest diameter ducting you can.

Functional

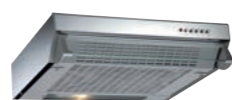

CST61
• Standard extractor
Details on [p66](#)



EIN60
• Integrated extractor
Details on [p66](#)



CCA52/72
• Under-canopy extractor
Details on [p67](#)



CTE61
• Telescopic extractor
Details on [p67](#)



CTE9
• Telescopic extractor
Details on [p68](#)

Chimney



ECH61/71/91/101
• Chimney extractor
Details on [p68](#)



ECP62/72/82/92/102/112
• Curved glass extractor
Details on [p69](#)



EKP60/70/90
• Curved glass extractor
Details on [p69](#)

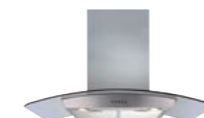

ECPK90
• Curved glass island extractor
Details on [p70](#)



EKPK90
• Curved glass island extractor with edge lighting
Details on [p70](#)



ECN62/72/92
• Flat glass extractor
Details on [p71](#)



EKN60/70/90
• Flat glass extractor with edge lighting
Details on [p71](#)



ECNK90
• Flat glass island extractor
Details on [p72](#)

Linear



EVP61/91/101/121
• Linear extractor
Details on [p72](#)

Angled



ECA60
• Angled extractor
Details on [p73](#)



EVA60/70/90
• Angled extractor
Details on [p74](#)



EVG6/9
• Angled extractor
Details on [p74](#)



EXA6080
• Angled extractor
Details on [p75](#)

Statement



EVQ71
• Circular extractor
Details on [p75](#)

Ceiling



EVX90
• Ceiling extractor
Details on [p76](#)



EVS90
• Star ceiling extractor
Details on [p76](#)

Downdraft



EDD62/92
• Downdraft extractor
Details on [p77](#)



3D9
• Downdraft extractor
Details on [p77](#)

Functional extractors



Stainless steel



White

CST61

Standard extractor

Features

- Ducted/re-circulating installation
- 3 speeds
- Push button control
- Aluminium grease filter
- 1 x 5.5W LED light
- Glass light di user

Optional accessories

- Ducting kit, AED51/53/54
- Charcoal filter for re-circulation, CHA36 (pack of 1)

Available in stainless steel, white

Energy efficiency rating: C

Technical specification

Required height over gas hob: **700mm (min.)**
 Required height over electric hob: **600mm (min.)**
 Outlet diameter: **120mm**
 Noise level: **68dBA**
 Extraction rate: **193m³/h**
 Rated electrical power: **70W**
 Power supply required: **3A**

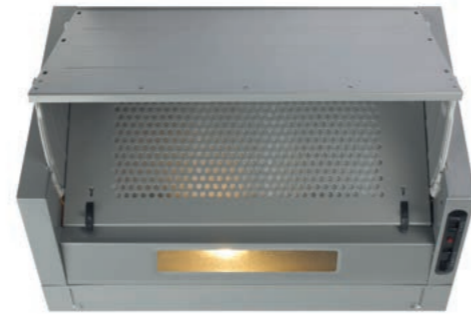
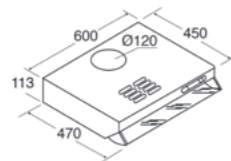

Silver

EIN60

Integrated extractor

Features

- Ducted/re-circulating installation
- 3 speeds
- Slider control
- 1 x 4W LED light

Optional accessories

- Ducting kit, AED51/53/54
- Charcoal filter for re-circulation, CHA15 (pack of 1)
- Aluminium grease filter, GRE3M
- Acrylic grease filter, GRE1

Available in silver; silver with aluminium grease filter, EIN60FSI

Energy efficiency rating: B

Technical specification

Required height over gas hob: **700mm (min.)**
 Required height over electric hob: **600mm (min.)**
 Outlet diameter: **120mm**
 Noise level: **62dBA**
 Extraction rate: **193m³/h**
 Rated electrical power: **49W**
 Power supply required: **3A**

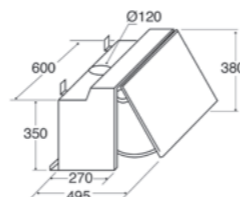

CCA52 - white



CCA72 - silver

CCA52/72

Canopy extractor

CCA52: 50cm wide/CCA72: 70cm wide

Features

- Ducted/re-circulating installation
- 3 speeds
- Push button control
- Aluminium grease filter
- 2 x 2WLED light

Optional accessories

- Ducting kit, AED51/53/54
- Charcoal filter for re-circulation, CHA15 (pack of 1)

CCA52 available in silver, white

CCA72 available in silver

Energy efficiency rating: B

Technical specification

Required height over gas hob: **700mm (min.)**
 Required height over electric hob: **600mm (min.)**
 Outlet diameter: **120mm**
 Noise level: **63dBA**
 Extraction rate: **206m³/h**
 Rated electrical power: **44W**
 Power supply required: **3A**

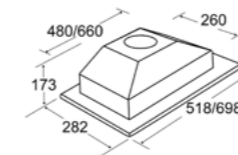

Open



Closed

CTE61

Telescopic extractor

Features

- Ducted/re-circulating installation
- 3 speeds
- Rocker switch
- Aluminium grease filter
- 2 x 3W LED lights

Optional accessories

- Ducting kit, AED51/53/54
- Charcoal filter for re-circulation, CHA34 (pack of 2)

Available in stainless steel

Energy efficiency rating: D

Technical specification

Required height over gas hob: **750mm (min.)**
 Required height over electric hob: **650mm (min.)**
 Outlet diameter: **120mm**
 Noise level: **59dBA**
 Extraction rate: **260m³/h**
 Rated electrical power: **131W**
 Power supply required: **3A**

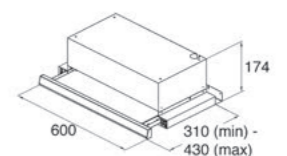

Functional extractors



Open



Closed

CTE9

Telescopic extractor

Features

- Ducted/re-circulating installation
- 3 speeds
- Rocker switch
- Aluminium grease filter
- 2 x 3W LED lights

Optional accessories

- Ducting kit, AED51/53/54
- Charcoal filter for re-circulation, CHA35 (pack of 2)

Available in stainless steel

Energy efficiency rating: D

Technical specification

Required height over gas hob: **750mm (min.)**
 Required height over electric hob: **650mm (min.)**
 Outlet diameter: **120mm**
 Noise level: **63dBA**
 Extraction rate: **367m³/h**
 Rated electrical power: **226W**
 Power supply required: **3A**

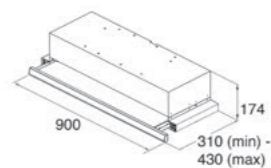

Chimney extractors



ECH61/71/91/101

Chimney extractor

ECH61: 60cm wide/**ECH71:** 70cm wide/
ECH91: 90cm wide/ **ECH101:** 101cm wide

Features

- Ducted/re-circulating installation
- 3 speeds
- Push button control
- Aluminium grease filters
- 2 x 3W LED lights
- Twin fan motor

Optional accessories

- Ducting kit, AED61/63/64
- Charcoal filter for re-circulation, CHA24 (pack of 2)

Available in stainless steel, black

Energy efficiency rating: D

Technical specification

Required height over gas hob: **700mm (min.)**
 Required height over electric hob: **600mm (min.)**
 Outlet diameter: **150mm**
 Noise level: **64dBA**
 Extraction rate: **427m³/h**
 Rated electrical power: **146W**
 Power supply required: **3A**

Fitting note

Please ensure that you check the ceiling height is sufficient to allow the required clearance between the hob and extractor.

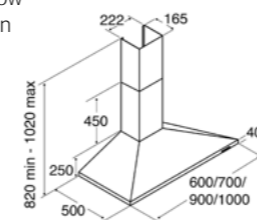

Stainless steel



Black

EKP60/70/90

Curved glass extractor with edge lighting

EKP60: 60cm wide/**EKP70:** 70cm wide/
EKP90: 90cm wide

Features

- Ducted/re-circulating installation
- 3 speeds
- Touch control
- Aluminium grease filters
- 2 x 2W LED lights
- 3W of edge lighting
- 9 minute timer

Optional accessories

- Ducting kits: 120mm, AED51/53/54
- Charcoal filter for re-circulation, CHA17 (pack of 2)

Available in stainless steel, black

Energy efficiency rating: D

Technical specification

Required height over gas hob: **700mm (min.)**
 Required height over electric hob: **600mm (min.)**
 Outlet diameter: **120mm**
 Noise level: **69dBA**
 Extraction rate: **336m³/h**
 Rated electrical power: **127W**
 Power supply required: **3A**

Fitting note

Please ensure that you check the ceiling height is sufficient to allow the required clearance between the hob and extractor.

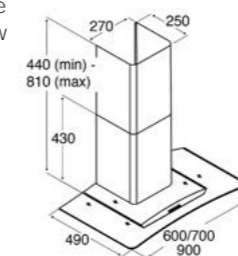

Stainless steel



Black

ECP62/72/82/92/102/112

Curved glass extractor

ECP62: 60cm wide/**ECP72:** 70cm wide/
ECP82: 80cm wide/ **ECP92:** 90cm wide
ECP102: 100cm wide/ **ECP112:** 110cm wide

Features

- Ducted/re-circulating installation
- 3 speeds
- Push button control
- Aluminium grease filters
- 2 x 2W LED lights

Optional accessories

- Ducting kits: 120mm, AED51/53/54; 150mm, AED61/63/64
- Charcoal filter for re-circulation, CHA12 (pack of 1)

Available in stainless steel, black

Energy efficiency rating: D

Technical specification

Required height over gas hob: **700mm (min.)**
 Required height over electric hob: **600mm (min.)**
 Outlet diameter: **120mm/150mm**
 Noise level: **60dBA**
 Extraction rate ECP62/72/82: **391m³/h**
 Extraction rate ECP92/102/112: **377m³/h**
 Rated electrical power: **104W**
 Power supply required: **3A**

Fitting note

Please ensure that you check the ceiling height is sufficient to allow the required clearance between the hob and extractor.

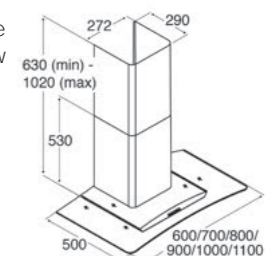

Chimney extractors



ECPK90

Curved glass island extractor

Features

- Ducted/re-circulating installation
- 3 speeds
- Push button control
- Aluminium grease filters
- 4 x 2W LED lights

Optional accessories

- Ducting kits: 120mm, AED51/53/54; 150mm, AED61/63/64
- Charcoal filter for re-circulation, CHA25 (pack of 2)

Available in stainless steel

Energy efficiency rating: D

Technical specification

Required height over gas hob: **700mm (min.)**
 Required height over electric hob: **600mm (min.)**
 Outlet diameter: **120mm/150mm**
 Noise level: **61dBA**
 Extraction rate: **387m³/h**
 Rated electrical power: **108W**
 Power supply required: **3A**

Fitting note

Please ensure that you check the ceiling height is sufficient to allow the required clearance between the hob and extractor.

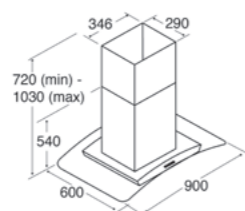

EKPK90

Curved glass island extractor with edge lighting

Features

- Ducted/re-circulating installation
- 3 speeds
- Touch control
- Aluminium grease filters
- 4 x 2W LED lights
- 3W of edge lighting
- Timer function

Optional accessories

- Ducting kits: 120mm, AED51/53/54; 150mm, AED61/63/64
- Charcoal filter for re-circulation, CHA12 (pack of 1)

Available in stainless steel, black

Energy efficiency rating: D

Technical specification

Required height over gas hob: **700mm (min.)**
 Required height over electric hob: **600mm (min.)**
 Outlet diameter: **120mm/150mm**
 Noise level: **61dBA**
 Extraction rate: **387m³/h**
 Rated electrical power: **111W**
 Power supply required: **3A**

Fitting note

Please ensure that you check the ceiling height is sufficient to allow the required clearance between the hob and extractor.

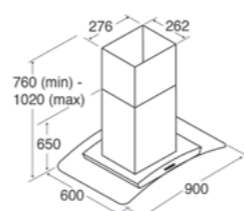

ECN62/72/92

Flat glass extractor

ECN62: 60cm wide/**ECN72:** 70cm wide/
ECN92: 90cm wide

Features

- Ducted/re-circulating installation
- 3 speeds
- Push button control
- Aluminium grease filter
- 2 x 2W LED lights

Optional accessories

- Ducting kits: 120mm, AED51/53/54; 150mm, AED61/63/64
- Charcoal filter for re-circulation, CHA12 (pack of 1)

Available in stainless steel, black

Energy efficiency rating: D

Technical specification

Required height over gas hob: **700mm (min.)**
 Required height over electric hob: **600mm (min.)**
 Outlet diameter **120mm/150mm**
 Noise level: **60dBA**
 Extraction rate: **391m³/h**
 Rated electrical power: **104W**
 Power supply required: **3A**

Fitting note

Please ensure that you check the ceiling height is sufficient to allow the required clearance between the hob and extractor.

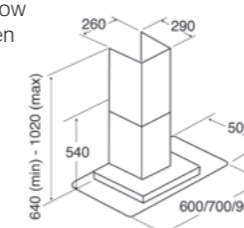

EKN60/70/90

Flat glass extractor with edge lighting

EKN60: 60cm wide/**EKN70:** 70cm wide/
EKN90: 90cm wide

Features

- Ducted/re-circulating installation
- 3 speeds
- Touch control
- Aluminium grease filter
- 2 x 2W LED lights
- 3W of edge lighting
- Timer function

Optional accessories

- Ducting kits: 120mm, AED51/53/54; 150mm, AED61/63/64
- Charcoal filter for re-circulation, CHA17 (pack of 2)

Available in stainless steel, black

Energy efficiency rating: D

Technical specification

Required height over gas hob: **700mm (min.)**
 Required height over electric hob: **600mm (min.)**
 Outlet diameter **120mm/150mm**
 Noise level: **69dBA**
 Extraction rate: **336m³/h**
 Rated electrical power: **127W**
 Power supply required: **3A**

Fitting note

Please ensure that you check the ceiling height is sufficient to allow the required clearance between the hob and extractor.

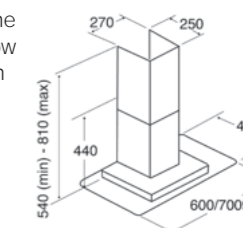

Chimney extractors



ECNK90

Flat glass island extractor

Features

- Ducted/re-circulating installation
- 3 speeds
- Push button control
- Aluminium grease filter
- 2 x 2W LED lights

Optional accessories

- Ducting kit, AED61/63/64
- Charcoal filter for re-circulation, CHA12 (pack of 1)

Available in stainless steel

Energy efficiency rating: A++

Technical specification

Required height over gas hob: **700mm (min.)**
 Required height over electric hob: **600mm (min.)**
 Outlet diameter: **150mm**
 Noise level: **61dBA**
 Extraction rate: **627m³/h**
 Rated electrical power: **74W**
 Power supply required: **3A**

Fitting note

Please ensure that you check the ceiling height is sufficient to allow the required clearance between the hob and extractor.

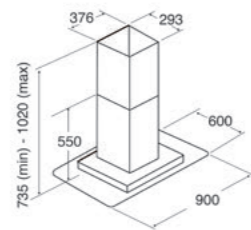

EVP61/91/101/121

Linear extractor

EVP61: 60cm wide/**EVP91:** 90cm wide/
EVP101: 101cm wide/**EVP121:** 120cm wide

Features

- Ducted/re-circulating installation
- 3 speeds + intensive
- Touch control
- Aluminium grease filters
- 2 x 2W LED lights
- Twin fan motor
- Filter saturation warning light
- Clean air function
- 15 minute timer

Optional accessories

- Ducting kit, AED61/63/64
- Charcoal filter for re-circulation, CHA21 (pack of 2)

Available in stainless steel

Energy efficiency rating: C

Technical specification

Required height over gas hob: **700mm (min.)**
 Required height over electric hob: **600mm (min.)**
 Outlet diameter: **150mm**
 Noise level: **62dBA**
 Extraction rate: **503m³/h**
 Rated electrical power: **252W**
 Power supply required: **3A**

Fitting note

Please ensure that you check the ceiling height is sufficient to allow the required clearance between the hob and extractor.

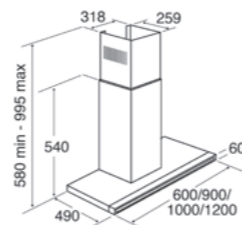

EVPK90

Linear island extractor

Features

- Ducted/re-circulating installation
- 3 speeds + intensive
- Touch control
- Aluminium grease filters
- 4 x 4W LED lights
- Twin fan motor
- Filter saturation warning light
- Clean air function
- 15 minute timer

Optional accessories

- Ducting kit, AED61/63/64
- Charcoal filter for re-circulation, CHA21 (pack of 2)

Available in stainless steel

Energy efficiency rating: C

Technical specification

Required height over gas hob: **700mm (min.)**
 Required height over electric hob: **600mm (min.)**
 Outlet diameter: **150mm**
 Noise level: **64dBA**
 Extraction rate: **520m³/h**
 Rated electrical power: **254W**
 Power supply required: **3A**

Fitting note

Please ensure that you check the ceiling height is sufficient to allow the required clearance between the hob and extractor.

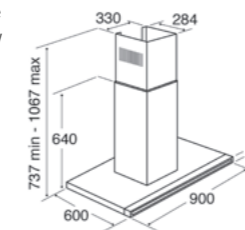

Angled extractors



ECA60

Angled extractor

Features

- Ducted/re-circulating installation
- 3 speeds
- Push button control
- Aluminium grease filter
- 2 x 2W LED lights
- Twin fan motor

Optional accessories

- Ducting kit, AED51/53/54
- Charcoal filter for re-circulation, CHA15 (pack of 1)

Available in black

Energy efficiency rating: B

Technical specification

Required height over gas hob: **550mm (min.)**
 Required height over electric hob: **550mm (min.)**
 Outlet diameter: **120mm**
 Noise level: **64dBA**
 Extraction rate: **350m³/h**
 Rated electrical power: **114W**
 Power supply required: **3A**

Fitting note

Please ensure that you check the ceiling height is sufficient to allow the required clearance between the hob and extractor.

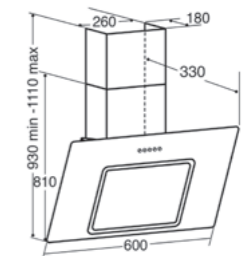

Angled extractors



EVA60



EVA90

EVA60/70/90

Angled extractor

EVA60: 60cm wide/**EVA70:** 70cm wide/
EVA90: 90cm wide

Features

- Ducted/re-circulating installation
- 3 speeds
- Touch control
- Aluminium grease filter
- 2 x 2W LED lights
- Twin fan motor
- 15 minute timer

Optional accessories

- Ducting kit, AED51/53/54
- Charcoal filter for re-circulation, CHA15 (pack of 1)

Available in black

Energy efficiency rating: B

Technical specification

Required height over gas hob: **550mm (min.)**
Required height over electric hob: **550mm (min.)**
Outlet diameter: **120mm**
Noise level: **64dBA**
Extraction rate: **350m³/h**
Rated electrical power: **114W**
Power supply required: **3A**

Fitting note

Please ensure that you check the ceiling height is sufficient to allow the required clearance between the hob and extractor.

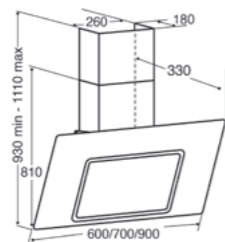

Black glass panel



Stainless steel

EVG6/9

Angled glass extractor

EVG6: 60cm wide/**EVG9:** 90cm wide

Features

- Ducted/re-circulating installation
- 3 speeds + intensive
- Touch control
- Aluminium grease filter
- 2 x 2W LED lights
- Twin fan motor
- Filter saturation warning light
- Clean air function
- 15 minute timer

Optional accessories

- Ducting kit, AED61/63/64
- Charcoal filter for re-circulation, CHA21 (pack of 2)

Available in stainless steel, black

Energy efficiency rating: C

Technical specification

Required height over CDA gas hob: **450mm (min.)**
Required height over non-CDA gas hob: **760mm (min.)**
Required height over CDA electric hob: **450mm (min.)**
Required height over non-CDA electric hob: **650mm (min.)**
Outlet diameter: **150mm**
Noise level: **58dBA**
Extraction rate: **422m³/h**
Rated electrical power: **252W**
Power supply required: **3A**

Fitting note

Please ensure that you check the ceiling height is sufficient to allow the required clearance between the hob and extractor.

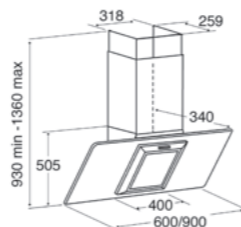

EXA60/80 - silver



EXA60 - black

EXA60/80

Angled extractor

EXA60: 60cm wide/**EXA80:** 80cm wide

Features

- Ducted/re-circulating installation
- 3 speeds + intensive
- Touch control
- Aluminium grease filter
- 1 x 6.5W LED strip light
- Filter saturation warning light
- Timer function

Optional accessories

- Ducting kit, AED61/63/64
- Charcoal filter for re-circulation, CHA14 (pack of 2)
- Re-circulating T piece, RTP01

EXA60 available in silver, black

EXA80 available in silver

Energy efficiency rating: A

Technical specification

Required height over gas hob: **495mm (min.)**
Required height over electric hob: **495mm (min.)**
Outlet diameter: **150mm**
Noise level EXA60: **62dBA**
Noise level EXA80: **59dBA**
Extraction rate EXA60: **610m³/h**
Extraction rate EXA80: **618m³/h**
Rated electrical power: **282W**
Power supply required: **3A**
Supplied with a UK plug

Fitting note

Please ensure that you check the ceiling height is sufficient to allow the required clearance between the hob and extractor.

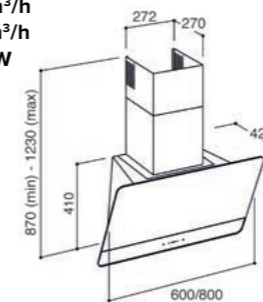

Statement extractor



EVQ71

Circular extractor

Features

- Ducted/re-circulating installation
- 3 speeds
- Touch control
- Aluminium grease filter
- 2 x 2W LED lights
- Timer function

Optional accessories

- Ducting kit, AED61/63/64
- Charcoal filter for re-circulation, CHA33 (pack of 2)

Available in stainless steel with black glass fascia

Energy efficiency rating: A++

Technical specification

Required height over gas hob: **700mm (min.)**
Required height over electric hob: **600mm (min.)**
Outlet diameter: **150mm**
Noise level: **62dBA**
Extraction rate: **579m³/h**
Rated electrical power: **74W**
Power supply required: **3A**

Fitting note

Please ensure that you check the ceiling height is sufficient to allow the required clearance between the hob and extractor.

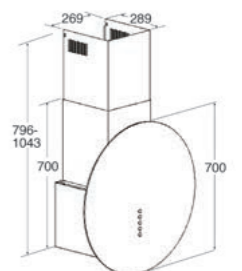

Ceiling extractors



EVX90

Ceiling extractor

Features

- Ducted/re-circulating installation
- 3 speeds
- Remote control
- Aluminium grease filter
- 4 x 4W LED lights
- Timer function
- External motor included

Accessories

- Remote control

Optional accessories

- Ducting kit, AED61/63/64
- Charcoal filter for re-circulation, CHA12 (pack of 1)

Available in stainless steel

Energy efficiency rating: B

Technical specification

Required height over gas hob: **750mm (min.)**
 Required height over electric hob: **750mm (min.)**
 Outlet diameter: **150mm**
 Noise level: **69dBA**
 Extraction rate: **650m³/h**
 Rated electrical power: **178W**
 Power supply required: **3A**

Fitting note

The extraction outlet can be rotated through 90°, 180° or 270°, allowing for flexible installation.

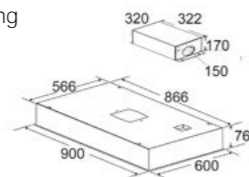

EVS90

Ceiling extractor

Features

- Ducted installation
- 2 speeds + 2 intensive
- Aluminium grease filters
- 20 x 0.95W Micro LED lights
- Timer function
- Peripheral aspiration
- External motor included
- Remote control

Optional accessories

- Ducting kit, AED61/63/64

Available in black

Energy efficiency rating: C

Technical specification

Required height over gas hob: **650mm (min.)**
 Required height over electric hob: **650mm (min.)**
 Outlet diameter: **150mm**
 Noise level: **61dBA**
 Extraction rate: **706m³/h**
 Rated electrical power: **355W**
 Power supply required: **3A**

Fitting note

Please ensure that you check the ceiling height is sufficient to allow the required clearance between the hob and extractor.

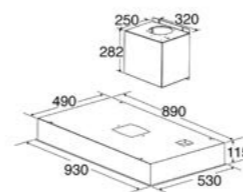

Downdraft extractors



EDD62/92

Downdraft extractor

EDD62: 60cm wide/EDD92 90cm wide

Features

- Ducted/re-circulating installation
- 3 speeds + intensive
- Touch control
- Aluminium grease filters
- 15 minute timer
- Synchronised sliding system
- Glass control panel
- Motor included

Optional accessories

- Ducting kit, AED61/63/64
- Charcoal filter for re-circulation: CHA12 (pack of 1)

Available in black

Energy efficiency rating: B

Technical specification

Outlet diameter: **150mm**
 Noise level EDD61: **66dBA**
 Noise level EDD91: **61dBA**
 Extraction rate: **566m³/h**
 Rated electrical power: **186W**
 Power supply required: **3A**

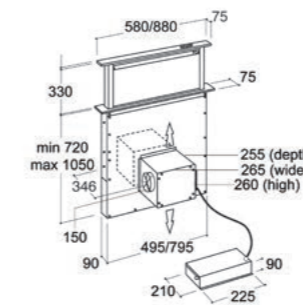

3D9

Downdraft extractor

Features

- Ducted/re-circulating installation
- 3 speeds + intensive
- Touch control
- Aluminium grease filters
- 1 x 14W neon light
- 10 minute timer
- Synchronised sliding system
- Glass control panel and side panel
- Motor included

Optional accessories

- Ducting kit, AED61/63/64
- Charcoal filter for re-circulation, CHA14 (pack of 2)

Available in black

Energy efficiency rating: A

Technical specification

Outlet diameter: **150mm**
 Noise level: **61dBA**
 Extraction rate: **605m³/h**
 Rated electrical power: **289W**
 Power supply required: **3A**

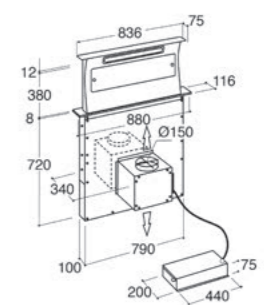

5

YEARS
PARTS

2 YEARS LABOUR



Refrigeration

Our refrigeration range includes all you need to keep your food fresh and tasty. With fantastic features across the range, CDA have options to suit your kitchen.

Under-counter cooling

Under-counter cooling is an ideal solution if you struggle for space or need extra storage. Our under-counter fridges and freezers will fit comfortably beneath your worktop without compromising on style and functionality. The **FW254** is full of handy features to help you store your weekly shop, including an ice box, salad crisper and in-door balconies.

Frost-free technology

Some appliances in our cooling range include useful frost-free technology that prevents the build-up of ice in the freezer compartment. This means that you will never have to defrost your freezer again!

LED interior lighting

LED interior lighting makes it easy to find what you're looking for, emits no heat and runs on very little energy.

Complete cooling system

For the ultimate cooling station, combine our **FF821** fridge and **FF881** freezer with our full height **FWC881** wine cooler.

Fitting together perfectly, these appliances create a high-capacity cooling centre for all types of fresh food and wine. The **FWC881** wine cooler is capable of holding a staggering 125 bottles of wine, whilst the **FF821** and **FF881** combined boast an impressive 660L capacity and offer endless storage possibilities.

This station is a great focal point in the kitchen and will complement any modern cooking space.

Quick guide to integrated refrigeration

Integrated models offer a variety of fridge, freezer and combination options to suit your kitchen.

All CDA fridges have an automatic self-defrosting feature so you never have to spend time defrosting your fridge.

Integrated refrigeration



FW224
• Under-counter larder fridge
Details on p82



FW254
• Under-counter fridge with ice box
Details on p82



FW284
• Under-counter freezer
Details on p83



FW321
• Under-counter larder fridge
Details on p83



FW381
• Under-counter freezer
Details on p84



FW422
• In-column larder fridge
Details on p84



FW482
• In-column freezer
Details on p85



FW522
• Three-quarter height larder fridge
• LED interior lighting
Details on p86



FW582
• Three-quarter height freezer
Details on p86



FW821
• Full height fridge
• LED interior lighting
Details on p87



FW881
• Full height freezer
Details on p87



FW822
• Full height freezer
• LED interior lighting
Details on p88



FW882
• Full height freezer
Details on p88



FW852
• 50/50 fridge freezer
• LED interior lighting
• Chrome bottle rack
Details on p89



FW872
• 70/30 fridge freezer
• LED interior lighting
• Chrome bottle rack
Details on p89



FW925
• 50/50 fridge freezer
• LED interior lighting
• Chrome bottle rack
Details on p90



FW927
• 70/30 fridge freezer
• LED interior lighting
• Chrome bottle rack
Details on p90



FW951
• 50/50 frost-free fridge freezer
• LED interior lighting
Details on p91



FW971
• 70/30 frost-free fridge freezer
• LED interior lighting
Details on p91

Freestanding refrigeration



FF821
• Full height larder fridge
• LED interior lighting
• Electronic control with LED display
Details on p92



FF881
• Full height freezer
• LED interior lighting
• Electronic control with LED display
Details on p92

New energy ratings due March 2021

Our energy ratings will be changing in accordance to the new EU regulations due March 2021.

Keep your eye out for more details

Integrated refrigeration



FW224

Integrated/under-counter larder fridge

Features

- Interior light
- 3 glass shelves
- 2 salad crisper compartments
- 2 in-door balconies
- 1 egg tray
- Height-adjustable feet
- Reversible door
- Fixed hinges

Energy consumption

Energy consumption per annum: **117kW.h**

Energy efficiency rating

- Energy rating: A+

Technical specification

Total usable capacity: **135L net**
Noise level: **41dBA**

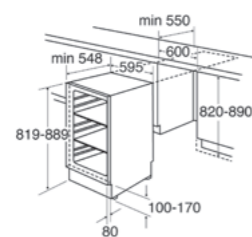

FW254

Integrated/under-counter fridge with ice box

Features

- Interior light
- 2 glass shelves
- 2 salad crisper compartments
- 2 in-door balconies
- 1 egg tray
- Height-adjustable feet
- Reversible door
- Fixed hinges

Ice box features

- 4 star rating
- 1 ice cube tray

Energy consumption

Energy consumption per annum: **173kW.h**

Energy efficiency rating

- Energy rating: A+

Technical specification

Fridge usable capacity: **95L net**
Ice box usable capacity: **16L net**
Total usable capacity: **111L net**
Freezing capacity: **2kg/24h**
Noise level: **41dBA**

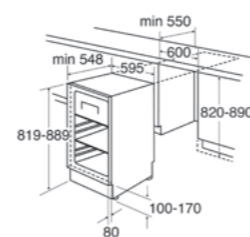

FW284

Integrated/under-counter freezer

Features

- 4 star rating
- 3 storage compartments
- 1 ice cube tray
- Height-adjustable feet
- Reversible door
- Fixed hinges

Energy consumption

Energy consumption per annum: **183kW.h**

Energy efficiency rating

- Energy rating: A+

Technical specification

Total usable capacity: **95L net**
Freezing capacity: **11kg/24h**
Noise level: **41dBA**

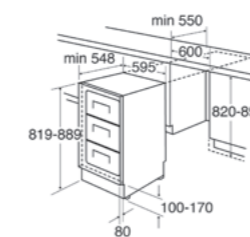

FW321

Integrated/under-counter larder fridge

Features

- Interior light
- 3 stainless-steel-edged glass shelves
- 1 salad crisper compartment
- 2 in-door balconies
- 1 egg tray
- Height-adjustable feet
- Reversible door
- Fixed hinges

Energy consumption

Energy consumption per annum: **115kW.h**

Energy efficiency rating

- Energy rating: A+

Technical specification

Total usable capacity: **133L net**
Noise level: **39dBA**

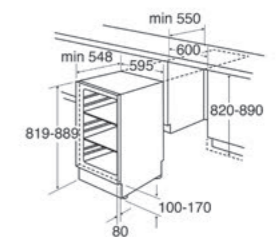

Integrated refrigeration



FW381

Integrated/under-counter freezer

Features

- 4 star rating
- 3 storage compartments
- 1 ice cube tray
- Height-adjustable feet
- Reversible door
- Fixed hinges

Energy consumption

Energy consumption per annum: **177kW.h**

Energy efficiency rating

- Energy rating: A+

Technical specification

Total usable capacity: **93L net**
 Freezing capacity: **9kg/24h**
 Noise level: **41dBA**

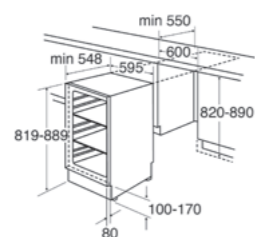

FW422

Integrated in-column larder fridge

Features

- Interior light
- 4 glass shelves
- 2 salad crisper drawers
- 3 in-door balconies
- 1 egg tray
- Reversible door
- Fixed hinges

Energy consumption

Energy consumption per annum: **121kW.h**

Energy efficiency rating

- Energy rating: A+

Technical specification

Total usable capacity: **134L net**
 Noise level: **41dBA**

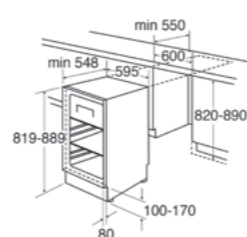

FW482

Integrated in-column freezer

Features

- 4 star rating
- 4 storage compartments
- 1 ice cube tray
- Reversible door
- Fixed hinges

Energy consumption

Energy consumption per annum: **195kW.h**

Energy efficiency rating

- Energy rating: A+

Technical specification

Total usable capacity: **99L net**
 Freezing capacity: **8kg/24h**
 Noise level: **39dBA**

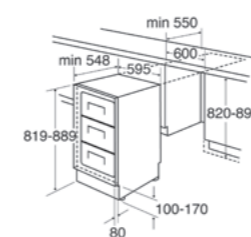

Integrated refrigeration



FW522

Integrated three-quarter height larder fridge

Features

- LED interior light
- 4 glass shelves
- 1 salad crisper drawer
- 3 in-door balconies
- 1 egg tray
- Height-adjustable feet
- Reversible door
- Fixed hinges

Energy consumption

Energy consumption per annum: **128kW.h**

Energy efficiency rating

- Energy rating: A+

Technical specification

Total usable capacity: **197L net**
Noise level: **41dBA**

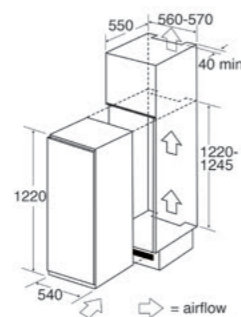

FW582

Integrated three-quarter height freezer

Features

- 4 star rating
- 5 storage compartments
- 1 ice cube tray
- Fast freeze
- Temperature warning light
- Height-adjustable feet
- Reversible door
- Fixed hinges

Energy consumption

Energy consumption per annum: **223kW.h**

Energy efficiency rating

- Energy rating: A+

Technical specification

Total usable capacity: **130L net**
Freezing capacity: **6.5kg/24h**
Noise level: **41dBA**

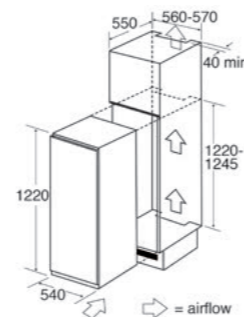

FW821

Integrated full height larder fridge

Features

- LED interior lighting
- 6 glass shelves
- 2 salad crisper drawers
- 5 in-door balconies
- 1 egg tray
- Front adjustable feet
- Reversible door
- Sliding furniture fixings

Energy consumption

Energy consumption per annum: **141kW.h**

Energy efficiency rating

- Energy rating: A+

Technical specification

Total usable capacity: **298L net**
Noise level: **39dBA**

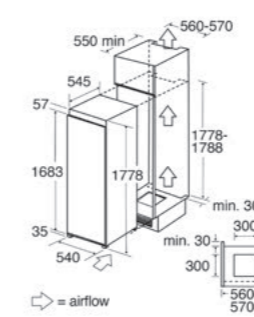

FW881

Integrated full height freezer

Features

- 4 star rating
- Temperature warning light
- Fast freeze
- 9 storage compartments
- 1 ice cube tray
- Front adjustable feet
- Reversible door
- Sliding furniture fixings

Energy consumption

Energy consumption per annum: **258kW.h**

Energy efficiency rating

- Energy rating: A+

Technical specification

Total usable capacity: **198L net**
Freezing capacity: **10.5kg/24h**
Noise level: **39dBA**

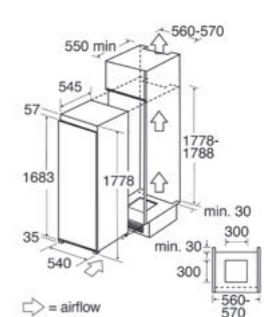

Integrated refrigeration



FW822

Integrated full height larder fridge

Features

- LED interior lighting
- Electronic temperature control
- 6 glass shelves
- 2 salad crisper drawers
- Chrome bottle rack
- 5 in-door balconies
- 1 egg tray
- Front adjustable feet
- Reversible door
- Sliding furniture fixings

Energy consumption

Energy consumption per annum: **147kW.h**

Energy efficiency rating

- Energy rating: A+

Technical specification

Total usable capacity: **316L net**
Noise level: **41dBA**

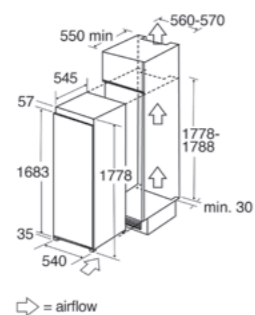

FW882

Integrated full height freezer

Features

- 4 star rating
- Electronic temperature control
- Frost-free
- Fast freeze
- 7 storage compartments
- 1 ice cube tray
- Front adjustable feet
- Reversible door
- Sliding furniture fixings

Energy consumption

Energy consumption per annum: **300kW.h**

Energy efficiency rating

- Energy rating: A+

Technical specification

Total usable capacity: **200L net**
Freezing capacity: **10.5kg/24h**
Noise level: **41dBA**

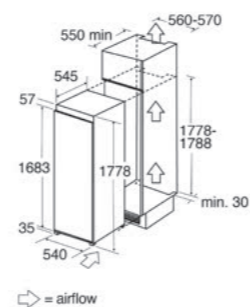

FW852

Integrated 50/50 combination fridge freezer

Features

- Reversible doors
- Sliding furniture fixings

Fridge features

- LED interior lighting
- Electronic control
- 3 glass shelves
- 2 salad crisper drawers
- 3 in-door balconies
- 1 egg tray
- Chrome bottle rack

Freezer features

- 4 star rating
- Fast freeze
- 4 storage compartments
- 1 ice cube tray

Energy consumption

Energy consumption per annum: **263kW.h**

Energy efficiency rating

- Energy rating: A+

Technical specification

Fridge usable capacity: **147L net**
Freezer usable capacity: **81L net**
Total usable capacity: **228L net**
Freezing capacity: **4.5kg/24h**
Noise level: **39dBA**

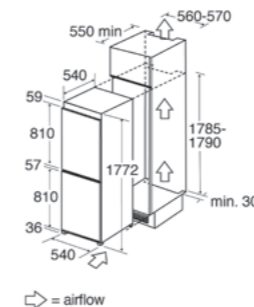

FW872

Integrated 70/30 combination fridge freezer

Features

- Reversible doors
- Sliding furniture fixings

Fridge features

- LED interior lighting
- Electronic control
- 4 glass shelves
- 2 salad crisper drawers
- 4 in-door balconies
- 1 egg tray
- Chrome bottle rack

Freezer features

- 4 star rating
- Fast freeze
- 3 storage compartments
- 1 ice cube tray

Energy consumption

Energy consumption per annum: **260kW.h**

Energy efficiency rating

- Energy rating: A+

Technical specification

Fridge usable capacity: **182L net**
Freezer usable capacity: **60L net**
Total usable capacity: **242L net**
Freezing capacity: **3.5kg/24h**
Noise level: **39dBA**

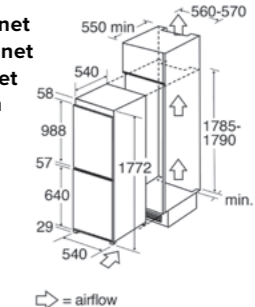

Integrated refrigeration



FW925

Integrated 50/50 combination frost-free fridge freezer

Features

- Reversible doors
- Sliding furniture fixings

Fridge features

- LED interior lighting
- Electronic control
- 4 glass shelves
- 2 salad crisper drawers
- 3 in-door balconies
- 1 egg tray
- Chrome bottle rack

Freezer features

- 4 star rating
- Frost-free
- 4 storage compartments
- 1 ice cube tray

Energy consumption

Energy consumption per annum: **280kW.h**

Energy efficiency rating

- Energy rating: A+

Technical specification

Fridge usable capacity: **158L net**
 Freezer usable capacity: **77L net**
 Total usable capacity: **235L net**
 Freezing capacity: **4.5kg/24h**
 Noise level: **41dBA**

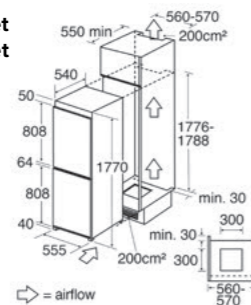

FW927

Integrated 70/30 combination frost-free fridge freezer

Features

- Reversible doors
- Sliding furniture fixings

Fridge features

- LED interior lighting
- Electronic control
- 5 glass shelves
- 1 salad crisper drawer
- 3 in-door balconies
- 1 egg tray
- Chrome bottle rack

Freezer features

- 4 star rating
- Frost-free
- 3 storage compartments
- 1 ice cube tray

Energy consumption

Energy consumption per annum: **270kW.h**

Energy efficiency rating

- Energy rating: A+

Technical specification

Fridge usable capacity: **190L net**
 Freezer usable capacity: **56L net**
 Total usable capacity: **246L net**
 Freezing capacity: **3.0kg/24h**
 Noise level: **41dBA**

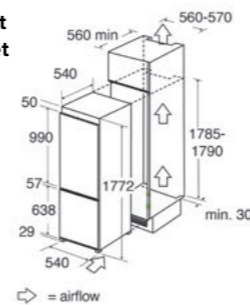

FW951

Integrated 50/50 combination frost-free fridge freezer

Features

- Reversible doors
- Fixed hinges

Fridge features

- Multi airflow cooling system
- LED interior lighting
- Super cool function
- Door open alarm
- Electronic control
- 4 glass shelves
- 1 variable humidity salad crisper drawer
- 3 in-door balconies
- 2 egg trays

Freezer features

- 4 star rating
- Frost-free
- Fast freeze
- 4 storage compartments
- 1 ice cube tray

Energy consumption

Energy consumption per annum: **312kW.h**

Energy efficiency rating

- Energy rating: A+

Technical specification

Fridge usable capacity: **148L net**
 Freezer usable capacity: **84L net**
 Total usable capacity: **232L net**
 Freezing capacity: **10kg/24h**
 Noise level: **39dBA**

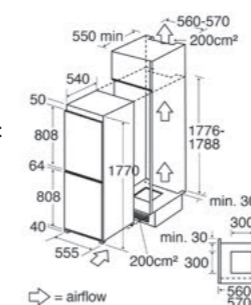

FW971

Integrated 70/30 combination frost-free fridge freezer

Features

- Reversible doors
- Fixed hinges

Fridge features

- Multi airflow cooling system
- LED interior lighting
- Super cool function
- Door open alarm
- Electronic control
- 5 glass shelves
- 1 variable humidity salad crisper drawer
- 3 in-door balconies
- 2 egg trays

Freezer features

- 4 star rating
- Frost-free
- Fast freeze
- 3 storage compartments
- 1 ice cube tray

Energy consumption

Energy consumption per annum: **300kW.h**

Energy efficiency rating

- Energy rating: A+

Technical specification

Fridge usable capacity: **179L net**
 Freezer usable capacity: **62L net**
 Total usable capacity: **241L net**
 Freezing capacity: **10kg/24h**
 Noise level: **39dBA**

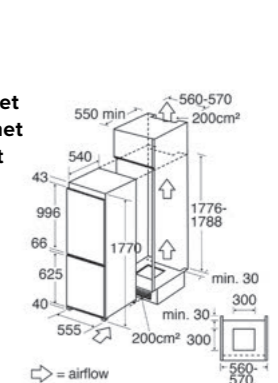

Freestanding refrigeration



ENERGY
A+



FF881

Freestanding full height frost-free freezer

Features

- Electronic control with LED display
- Temperature rise signal
- LED interior lighting
- 4 star rating
- Fast freeze
- 7 storage compartments
- Ice cube tray
- Frost-free
- Front adjustable feet
- Reversible door

Available in stainless steel effect

Energy consumption

Energy consumption per annum: **328kW.h**

Energy efficiency rating

- Energy rating: A+

Technical specification

Total usable capacity: **280L net**
Freezing capacity: **21kg/24h**
Noise level: **42dBA**

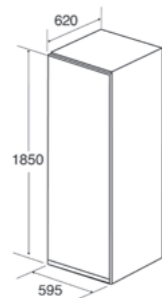

ENERGY
A+



FF821

Freestanding full height larder fridge

Features

- Electronic control with LED display
- Temperature rise signal
- LED interior lighting
- 5 adjustable glass shelves
- 2 salad crispers
- 5 in-door balconies
- Super cooling
- Front adjustable feet
- Reversible door

Available in stainless steel effect

Energy consumption

Energy consumption per annum: **169kW.h**

Energy efficiency rating

- Energy rating: A+

Technical specification

Total usable capacity: **380L net**
Noise level: **41dBA**

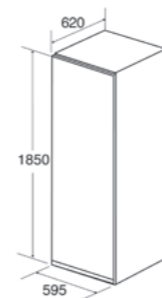

The ultimate cooling station

Combine:

- **FF821** (p92)
- **FF881** (p92)
- **FWC881** (p100)



5

YEARS
PARTS

2 YEARS LABOUR



Wine coolers

Using anti-vibration technology, UV-protection and temperature control, CDA wine coolers keep your collection in optimum condition.

UV-protective glass doors

All CDA wine coolers have UV-protective, toughened, smoked glass doors to prevent sunlight spoiling the wine. This also assists thermal efficiency.

A-rated energy efficiency

As we continually move forward and improve our products in response to new technology, our latest range of wine coolers has improved efficiency ratings to save on energy usage in your home.

Wine cooler glass shelf

Our optional wine cooler glass shelf is perfect for storing smaller items such as bottles and cans - compatible with the **FWC304**, **FWC604**, **FWC624** and **FWC881** models. Please see our accessory section for details.

LED lighting

Bright LED lighting illuminates the internal cavity beautifully and makes finding the right bottle quick and easy.

Luxury wooden shelving

Our wine coolers feature luxury solid wooden shelves as standard (excludes 15cm slimline models). The **FWV902** integrated model also has the addition of a luxury wooden display shelf.

Digital temperature control

All CDA wine coolers are designed with electronic temperature control, which is adjustable between 5°C and 20°C. The red digital display is easy to use and has a convenient memory function.

Quick guide to wine coolers

All our wine coolers feature the characteristic sleek, minimalist design of the CDA range.

A wide variety of sizes are available, meaning there's one to suit every kitchen space.

Improved safety

Variations in temperature, light and movement can all accelerate the ageing process of wine and damage your collection. All of our wine coolers come with the latest technology to provide the perfect storage solution. As part of our continued commitment to safety, we have now introduced metal backing to our wine cooler range.

Wine coolers



FWC153

- Freestanding/under-counter slimline wine cooler
Details on [p98](#)



FWC304

- Freestanding/under-counter slimline wine cooler
Details on [p98](#)



FWC604

- Freestanding/under-counter wine cooler
Details on [p99](#)



FWC624

- Freestanding/under-counter double door wine cooler
Details on [p99](#)



FWC881

- Full height freestanding wine cooler
Details on [p100](#)



FWV902

- Integrated wine cooler
Details on [p100](#)

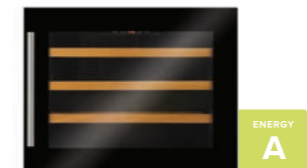

FWV452

- Integrated compact wine cooler
Details on [p101](#)

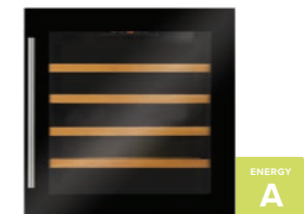

FWV601

- Integrated compact wine cooler
Details on [p101](#)

New energy ratings due March 2021

Our energy ratings will be changing in accordance to the new EU regulations due March 2021.

Keep your eye out for more details

Wine coolers



FWC153

Freestanding/under-counter slimline wine cooler

Features

- 7 (75cL Bordeaux) total bottle storage
- Black plinth
- Red digital display
- Single temperature storage zone
- 6 integrated supports
- Electronic temperature control
- UV-protective toughened smoked glass door
- Double glazed door
- LED interior lighting
- Temperature memory function
- Over temperature alarm
- Height-adjustable plinth section
- Door open alarm
- Compressor driven

Available in stainless steel, black glass

Energy consumption

Energy consumption per annum: **185kW.h**

Energy efficiency rating: B

Technical specification

Reversible door
 Rated electrical power: **60W**
 Power supply required: **13A**
 Noise level: **40dBA**
 Temperature range: **5°C to 20°C**

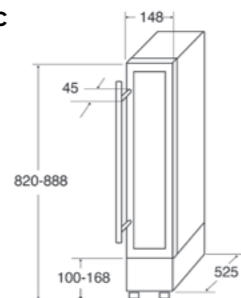

FWC304

Freestanding/under-counter slimline wine cooler

Features

- 20 (75cL Bordeaux) total bottle storage
- Black plinth
- Red digital display
- Single temperature storage zone
- 5 wooden slide-out shelves
- Electronic temperature control
- UV-protective toughened smoked glass door
- Double glazed door
- LED interior lighting
- Temperature memory function
- Over temperature alarm
- Height-adjustable plinth section
- Humidifier to maintain 50-80% RH
- Door open alarm
- Compressor driven

Available in stainless steel, black glass

Optional accessories

- Glass shelves (pack of 3), AFG31

Energy consumption

Energy consumption per annum: **138kW.h**

Energy efficiency rating: A

Technical specification

Reversible door
 Rated electrical power: **85W**
 Power supply required: **13A**
 Noise level: **39dBA**
 Temperature range: **5°C to 20°C**

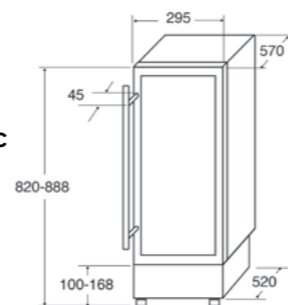

FWC604

Freestanding/under-counter wine cooler

Features

- 45 (75cL Bordeaux) total bottle storage
- Black plinth
- Red digital display
- Dual temperature storage zones
- 5 wooden slide-out shelves
- Electronic temperature control
- UV-protective toughened smoked glass door
- Double glazed door
- LED interior lighting
- Temperature memory function
- Over temperature alarm
- Height-adjustable plinth section
- Integral heater
- Humidifier to maintain 50-80% RH
- Door open alarm
- Compressor driven

Available in stainless steel, black glass

Optional accessories

- Glass shelves (pack of 3), AFG61

Energy consumption

Energy consumption per annum: **180kW.h**

Energy efficiency rating: B

Technical specification

Reversible door
 Rated electrical power: **100W**
 Power supply required: **13A**
 Noise level: **39dBA**

Upper zone

Temperature range: **5°C to 20°C**
 Stores 15 (75cL Bordeaux) bottles

Lower zone

Temperature range: **5°C to 20°C**
 Stores 5 (75cL Bordeaux) bottles

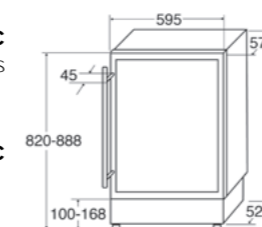

FWC624

Freestanding/under-counter double door wine cooler

Features

- 38 (75cL Bordeaux) total bottle storage
- Black plinth
- Red digital display
- Dual temperature storage zones
- 11 wooden slide-out shelves
- Electronic temperature control
- UV-protective toughened smoked glass door
- Triple glazed door
- LED interior lighting
- Temperature memory function
- Over temperature alarm
- Height-adjustable plinth section
- 2 humidifiers to maintain 50-80% RH
- Door open alarm
- Compressor driven

Available in stainless steel, black glass

Optional accessories

- Glass shelves (pack of 3), AFG31

Energy consumption

Energy consumption per annum: **190kW.h**

Energy efficiency rating: B

Technical specification

Rated electrical power: **100W**
 Power supply required: **13A**
 Noise level: **40dBA**

Left zone

Temperature: **5°C to 20°C**
 Stores 20 (75cL) bottles

Right zone

Temperature: **5°C to 20°C**
 Stores 18 (75cL) bottles

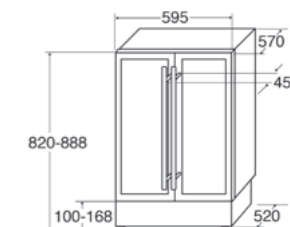

Wine coolers



FWC881

Full height freestanding wine cooler

Features

- 117 (75cL Bordeaux) total bottle storage
- Black plinth
- Red digital display
- Dual temperature storage zones
- 14 wooden slide-out shelves
- Electronic temperature control
- UV-protective toughened smoked glass door
- Triple glazed door
- LED interior lighting
- Energy saving mode
- Temperature memory function
- Over temperature alarm
- Door open alarm
- Humidifier in upper zone to maintain 50-80% RH
- Integral heater
- Compressor driven

Available in black

Optional accessories

- Glass shelves (pack of 3), AFG61

Energy consumption

Energy consumption per annum: **160kW.h**

Energy efficiency rating: A

Technical specification

Height-adjustable feet
Reversible door
Rated electrical power: **160W**
Power supply required: **13A**
Noise level: **41dBA**

Upper zone

Temperature range: **5°C to 20°C**
Stores 63 (75cL Bordeaux) bottles

Lower zone

Temperature range: **5°C to 20°C**
Stores 63 (75cL Bordeaux) bottles

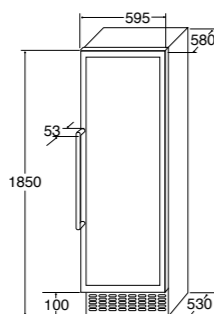

FWV902

Integrated wine cooler

Features

- 57 (75cL Bordeaux) total bottle storage without display shelf
- Red digital display
- Dual temperature storage zones
- 5 wooden slide-out shelves and 1 wooden display shelf
- Electronic temperature control
- UV-protective toughened smoked glass door
- Triple glazed door
- LED interior lighting
- Temperature memory function
- Over temperature alarm
- Door open alarm
- Energy saving mode
- Display light function
- Humidifier to maintain 50-80% RH
- Compressor driven

Available in black

Energy consumption

Energy consumption per annum: **195kW.h**

Energy efficiency rating: B

Technical specification

Reversible door
Rated electrical power: **100W**
Power supply required: **13A**
Noise level: **40dBA**

Upper zone

Temperature range: **5°C to 20°C**
Stores 22 (75cL Bordeaux) bottles

Lower zone

Temperature range: **5°C to 20°C**
Stores 35 (75cL Bordeaux) bottles or 30 when using display shelf

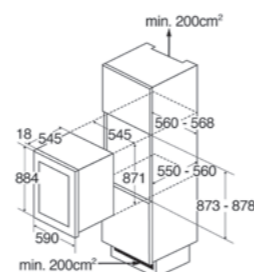

FWV452

Integrated compact wine cooler

Features

- 24 (75cL Bordeaux) total bottle storage
- Red digital display
- Single temperature storage zone
- 3 wooden slide-out shelves
- Electronic temperature control
- UV-protective toughened smoked glass door
- Triple glazed door
- Reversible door
- LED interior lighting
- Temperature memory function
- Over temperature alarm
- Door open alarm
- Energy saving mode
- Display light function
- Humidifier to maintain 50-80% RH
- Compressor driven

Available in black

Energy consumption

Energy consumption per annum: **140kW.h**

Energy efficiency rating: A

Technical specification

Rated electrical power: **85W**
Power supply required: **13A**
Noise level: **39dBA**
Temperature range: **5°C to 20°C**

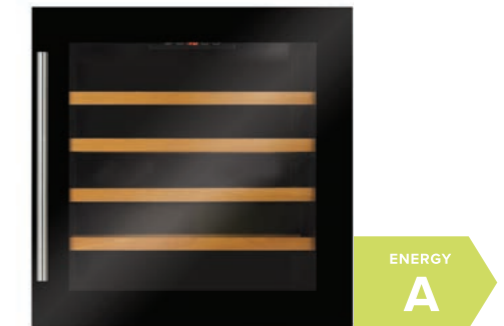
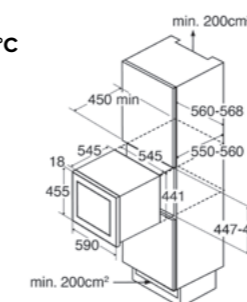

FWV601

Integrated compact wine cooler

Features

- 40 (75cL Bordeaux) total bottle storage
- Red digital display
- Single temperature storage zone
- 4 wooden slide-out shelves
- Electronic temperature control
- UV-protective toughened smoked glass door
- Triple glazed door
- Reversible door
- LED interior lighting
- Temperature memory function
- Over temperature alarm
- Door open alarm
- Energy saving mode
- Display light function
- Humidifier to maintain 50-80% RH
- Compressor driven

Available in black

Energy consumption

Energy consumption per annum: **140kW.h**

Energy efficiency rating: A

Technical specification

Reversible door
Rated electrical power: **100W**
Power supply required: **13A**
Noise level: **39dBA**
Temperature range: **5°C to 20°C**

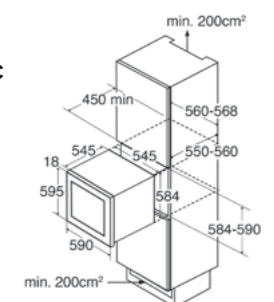

5

YEARS
PARTS

2 YEARS LABOUR



Dishwashers

CDA dishwashers have been designed with function and performance in mind. Combining energy-saving features and intelligent technology, they deliver perfect results every time.

Flood protection

All our dishwashers come complete with a leak detection function to help avoid flood damage in your home. For total peace of mind, the Aquastop system in models like the **WC680** dishwasher will automatically cut off the water supply in the event of a leak or flood being detected.

Drying

Active drying on models like the **WC680** means that your dishwasher doesn't rely on passive heat to dry the dishes. Instead, it forces air around the cavity using a fan, drying them quickly and efficiently.

Water consumption

It is a common misconception that dishwashers use more water than hand washing. The average household will complete two lots of hand washing per day, using 21 litres of water

each time. In comparison, CDA dishwashers use between just 9 and 12 litres of water per load, and hold up to 15 place settings. This makes using a CDA dishwasher a far more efficient and environmentally friendly way to take care of the dishes.

Top level cutlery drawer

The **WC680** features a useful top cutlery drawer with easy grip handles - simply pull the drawer out to retrieve your clean cutlery. Not only this, but the lower compartment comes with folding racks and a height-adjustable upper basket to create more space for those larger pots and pans.

A++ energy efficiency

Our dishwasher models have all been rated A++ for energy efficiency, ensuring that they use the least amount of water possible to give brilliant wash results, while also minimising energy usage.

Quick guide to dishwashers

CDA dishwashers combine state-of-the-art technology with meticulous build quality to give you reliable performance for years to come.

All our dishwashers feature:

- A++ rating for energy efficiency
- Cold water fill
- Counter-balanced door
- Upper height-adjustable basket to accommodate larger items
- Concealed heating element to protect the bottom basket
- Delay timer to take advantage of off-peak electricity

Dishwashers



WC432

- **Slimline integrated dishwasher**
- 10 place settings
- 6 programmes
- Delay timer
- Intensive+ 700C
- Details on **p106**



WC480

- **Slimline integrated dishwasher**
- 10 place settings
- 8 programmes
- Delay timer
- Half load
- Top level cutlery basket
- GlassGuard
- Variospace holder (optional)
- Details on **p107**



WC142

- **Integrated dishwasher**
- 13 place settings
- 5 programmes
- Delay timer
- Intensive 700C
- Details on **p106**



WC371

- **Integrated dishwasher**
- 13 place settings
- 9 programmes
- Delay timer
- Half load
- Intensive+ 700C
- Variospace holder (optional)
- Details on **p108**



WC680

- **Integrated dishwasher**
- 15 place settings
- 8 programmes
- Delay timer
- Half load
- Top level cutlery drawer
- Triple wash
- GlassGuard
- Variospace holder (optional)
- Details on **p109**

New energy ratings due March 2021

Our energy ratings will be changing in accordance to the new EU regulations due March 2021.

Keep your eye out for more details

Product specific features

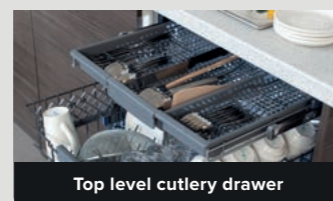
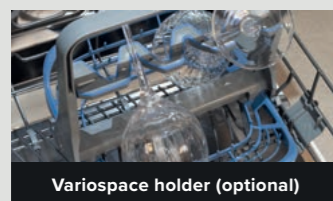
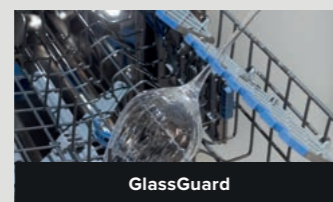
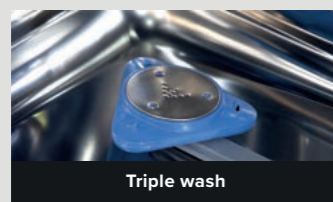

Dishwashers



WC432

Integrated slimline dishwasher

Features

- 10 place settings
- Half load
- 3/6/9 hour delay timer
- 3 spray levels
- LED rinse aid indicator
- LED salt indicator
- LED progress indicator
- Acoustic signal for end of programme
- Electronic softener adjustment
- Height-adjustable upper basket
- Overflow protection
- Levelling feet with front control
- Grey baskets

6 programmes

- Prewash (cold)
- Quick wash 40°C
- Eco 50°C
- Express 65°C
- Intensive 65°C
- Intensive+ 70°C

Energy consumption

Energy consumption per cycle: **0.73kW.h**
 Water consumption per cycle: **11L**
 Energy consumption per annum: **211kW.h**
 Water consumption per annum: **3080L**

Energy efficiency rating

- Energy rating: A++
- Wash rating: A
- Drying rating: A

Technical specification

Rated electrical power: **1.9kW**
 Power supply required: **13A**
 Noise level: **49dBA**

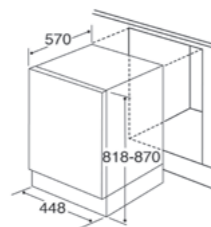

WC142

Integrated dishwasher

Features

- 13 place settings
- 3/6/9 hour delay timer
- 2 spray levels
- LED rinse aid indicator
- LED salt indicator
- Acoustic signal for end of programme
- Electronic softener adjustment
- Levelling feet with front control
- Height-adjustable upper basket
- White baskets

5 programmes

- Prewash (cold)
- Quick wash 40°C
- Eco 50°C
- Super 65°C
- Intensive 70°C

Energy consumption

Energy consumption per cycle: **0.9kW.h**
 Water consumption per cycle: **12L**
 Energy consumption per annum: **261kW.h**
 Water consumption per annum: **3360L**

Energy efficiency rating

- Energy rating: A++
- Wash rating: A
- Drying rating: A

Technical specification

Rated electrical power: **1.9kW**
 Power supply required: **13A**
 Noise level: **49dBA**

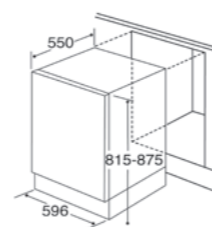

WC480

Integrated intelligent slimline dishwasher

Features

- 10 place settings
- Half load operates either upper or lower baskets individually or half load of both baskets
- 1-19 hour delay timer
- 3 spray levels
- LED rinse aid indicator
- LED salt indicator
- Acoustic signal for end of programme
- Electronic softener adjustment
- 3-in-1 function
- Levelling feet with front control
- Height-adjustable upper basket when loaded
- Overflow protection
- Top level cutlery drawer

8 programmes

- Prewash (cold)
- Quick wash 40°C
- Eco 50°C
- 50 minute express wash 65°C
- Intensive+ 70°C
- Auto delicate 30-50°C
- Auto normal 50-60°C
- Auto intensive 60-70°C

Energy efficiency rating

- Energy rating: A++
- Wash rating: A
- Drying rating: A

Energy consumption

Energy consumption per annum: **211kW.h**
 Water consumption per annum: **2520L**
 Energy consumption per cycle: **0.73kW.h**
 Water consumption per cycle: **9L**

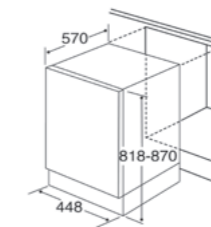

Technical specification

Rated electrical power: **1.9kW**
 Power supply required: **13A**
 Noise level: **45dBA**



WC371

Integrated intelligent dishwasher

Features

- 13 place settings
- Half load operates either upper or lower baskets individually or half load of both baskets
- 1-19 hour delay timer
- 3 spray levels
- LED rinse aid indicator
- LED salt indicator
- Acoustic signal for end of programme
- Electronic softener adjustment
- 3-in-1 function
- Levelling feet with front control
- Height-adjustable upper basket when loaded
- GlassGuard - wine glass supports
- Grey baskets

9 programmes

- Prewash (cold)
- Quick wash 40°C
- Eco 50°C
- 55 minute express wash 60°C
- Delicate 30 - 50°C
- Auto normal 50-60°C
- Auto intensive 60-70°C
- Intensive 60°C
- Intensive+ 70°C

Energy consumption

Energy consumption per annum: **261kW.h**
 Water consumption per annum: **2520L**
 Energy consumption per cycle: **0.9kW.h**
 Water consumption per cycle: **9L**

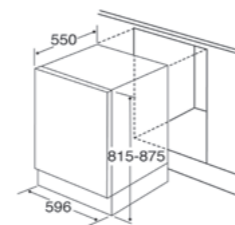

Energy efficiency rating

- Energy rating: A++
- Wash rating: A
- Drying rating: A

Technical specification

Rated electrical power: **1.9kW**
 Power supply required: **13A**
 Noise level: **45dBA**



WC680

Integrated intelligent dishwasher

Features

- 15 place settings
- LED interior light
- Half load operates either upper or lower baskets individually or half load of both baskets
- 1-19 hour delay timer
- 3 spray levels with the addition of triple wash
- Direct wash
- Triple wash
- LED rinse aid indicator
- LED salt indicator
- Acoustic signal for end of programme
- Electronic softener adjustment
- Active drying system
- 3-in-1 function

8 programmes

- Prewash (cold)
- Super quick wash (14 minutes) 30°C
- Quick wash 40°C
- Eco 50°C
- Super 50 65°C
- Hygiene 60°C
- Auto delicate 30-50°C
- Auto normal 50-60°C
- Auto intensive 60-70°C

Energy consumption

Energy consumption per annum: **267kW.h**
 Water consumption per annum: **2520L**
 Energy consumption per cycle: **0.94kW.h**
 Water consumption per cycle: **9L**

Energy efficiency rating

- Energy rating: A++
- Wash rating: A
- Drying rating: A

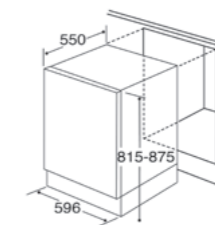

5
YEARS
PARTS

2 YEARS LABOUR



Laundry

Our washing machines make it easy to tackle the laundry. Equipped with the latest programmes and features, they make efficient use of water and energy.

Our wide range of products

CDA's range consists of integrated washing machines and washer dryers. We are constantly testing, improving and developing our technology to ensure that you benefit from the most energy-efficient and effective appliances possible, whichever model you choose.

Quick wash

We have developed a super quick wash programme that can complete a cycle in just 15 minutes. Whether you have forgotten to wash your favourite jeans, or need a helping hand with those tedious laundry tasks, the quick wash feature is available on all of our washing machines and washer dryers.

Advanced technology

High energy ratings are important on appliances like washing machines, as they are used frequently and can make up a large proportion of your energy bills.

Additional digital sensors on our laundry machines work with your spin cycle, water inlet and drying times to adjust the settings to achieve perfect results, every time.

Save your favourite settings

The **CI361**, **CI381** and **CI981** have an additional **MyChoice** feature, which allows you to save the programmes and options you use most often.

Quick guide to laundry

The CDA laundry range includes a variety of integrated washing machines and washer dryers.

All CDA washing machines and washer dryers have the following features:

- Robust stainless steel drum
- Safety door lock
- Cold water fill
- Compatible with a full height furniture door, which can be hinged on the right or left

New energy ratings due March 2021

Our energy ratings will be changing in accordance to the new EU regulations due March 2021.

Keep your eye out for more details

MyChoice

The **C1361**, **C1381** and **C1981** have an additional MyChoice feature, which allows you to save the programmes and options you use most often.

Integrated washing machines



C1361

- 1200 spin speed
 - 6kg wash load
 - MyChoice feature
- Details on p113

C1326

- 1200 spin speed
 - 7kg wash load
- Details on p113



C1381

- 1400 spin speed
 - 8kg wash load
 - MyChoice feature
- Details on p114

Integrated washer dryers



C1981

- 1400 spin speed
 - 8 + 6kg wash/dry load
 - MyChoice feature
- Details on p115

Integrated washing machines



C1361

Integrated washing machine

Features

- 1200rpm spin speed
- 16 programmes
- 6kg wash load
- Delay timer
- Variable spin speed
- Variable wash temperature
- 15 minute quick wash
- Delicates wash
- Wool wash
- Sport wash
- LED display
- Safety key lock
- **MyChoice**
- Extra rinse function
- Acoustic signal for end of programme

Available in white

Energy consumption

Energy consumption per cycle: **0.88kW.h**
 Water consumption per cycle: **48L**
 Energy consumption per annum: **173kW.h**
 Water consumption per annum: **9240L**

Energy efficiency rating

- Energy rating: A++
- Wash rating: A

Technical specification

Rated electrical power: **2.1kW**
 Power supply required: **13A**
 Noise level: **wash 57/ spin 74dBA**

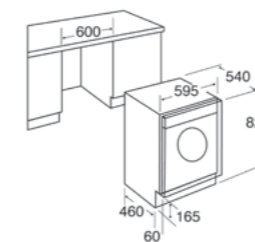

C1326

Integrated washing machine

Features

- 1200rpm spin speed
- 11 programmes
- 7kg wash load
- Delay timer
- Variable spin speed
- Variable wash temperature
- 15 minute quick wash
- Delicates wash function
- Cold wash
- Wool wash
- LED display
- Safety key lock
- Anti-crease function
- Extra rinse function
- Intensive wash function
- Acoustic signal for end of programme

Available in white

Energy consumption

Energy consumption per cycle: **0.495kW.h**
 Water consumption per cycle: **49L**
 Energy consumption per annum: **108kW.h**
 Water consumption per annum: **9900L**

Energy efficiency rating

- Energy rating: A+++
- Wash rating: A
- Spin rating: B

Technical specification

Rated electrical power: **1.9kW**
 Power supply required: **13A**
 Noise level: **wash 56/spin 78dBA**

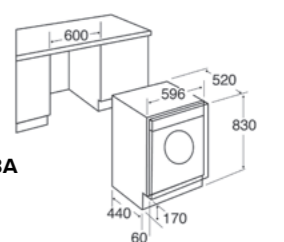

Integrated washing machines



CI381

Integrated washing machine

Features

- 1400rpm spin speed
- 16 programmes
- 8kg wash load
- Delay timer
- Variable spin speed
- Variable wash temperature
- 15 minute quick wash
- Delicates wash
- Wool wash
- Sport wash
- LED display
- Safety key lock
- **MyChoice**
- Extra rinse function
- Acoustic signal for end of programme

Available in white

Energy consumption

Energy consumption per cycle: **0.94kW.h**
 Water consumption per cycle: **54L**
 Energy consumption per annum: **196kW.h**
 Water consumption per annum: **11000L**

Energy efficiency rating

- Energy rating: A+++
- Wash rating: A

Technical specification

Rated electrical power: **2kW**
 Power supply required: **13A**
 Noise level: **wash 57/**
spin 76dBA

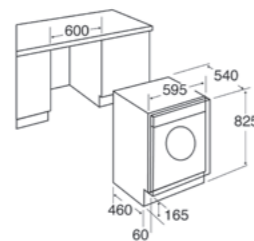

Integrated washer dryers



CI981

Integrated washer dryer

Features

- 1400rpm spin speed
- 16 programmes
- 8kg wash load
- 6kg dry load
- Delay timer
- Variable spin speed
- Variable wash temperature
- 15 minute quick wash
- Delicates setting
- **MyChoice**
- LED display
- Extra rinse function
- Acoustic signal for end of programme
- Condensing dryer
- Safety key lock
- Balance control
- Over-flow protection

Available in white

Energy consumption

Energy consumption per cycle: **5.44kW.h**
 Water consumption per cycle: **152L**
 Energy consumption per annum: **1088kW.h**
 Water consumption per annum: **30400L**

Energy efficiency rating

- Energy rating: A
- Wash rating: A

Technical specification

Rated electrical power: **1.9kW**
 Power supply required: **13A**
 Noise level: **wash 54/spin 78/**
dry 62dBA

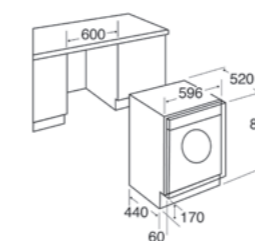



Sinks

The CDA sink range includes inset and undermount options in stainless steel, composite and ceramic, with styles that complement both contemporary and traditional kitchens.

Stainless steel

Our **TF55** tap filters mains tap water to improve its taste, clarity and odour. Mains water is passed through a cartridge concealed under the sink and is controlled through the tap by a simple lever action.

Composite

Our composite sink range can withstand temperatures of up to 280°C. Made from a mixture of quartz or granite blended with acrylic resin for durability, our composite sinks are hard-wearing and combine the natural look of stone with the benefits of a modern material.

Ceramic

Made from incredibly robust, fine fireclay with a hard, glossy finish, these sinks are easy to clean and extremely durable. Our choice of styles includes contemporary single or one-and-a-half bowl sinks, traditional Belfast styles and even ceramic undermount sinks. Our ceramic sinks are traditionally made, and each one has individual characteristics. The natural materials used create unique marks and patterns, giving each unit real character.

Seamless finish

If you are looking for a heavy-grade, minimally styled inset sink, the **KVF21** and **KVF22L** are designed to fit flush with your worktops, creating a stylish and contemporary look. Alternatively, the entire undermount sink range offers a seamless finish.

Quick guide to inset sinks

The CDA range of sinks includes stainless steel, ceramic and composite models.

Most CDA sinks are supplied with pipework and have large 3.5" strainer wastes.

Inset sinks make a bold statement, with many offering built-in draining options. The range of materials are designed to complement any worktop surface.

Stainless steel



KR20
• 1 bowl round drainer
Details on [p123](#)



KR21
• 1 bowl round sink
Details on [p123](#)



KA30
• Compact 1 bowl sink
• Reversible
Details on [p126](#)



KA32
• 1.5 bowl sink
• Reversible
Details on [p126](#)



KA72
• 1.5 bowl sink
• Reversible
Details on [p129](#)



KA80
• 1 bowl sink
• Reversible
Details on [p129](#)



CCP3
• 2 bowl corner sink
• Polished finish
Details on [p124](#)



KA20
• Compact 1 bowl sink
• Reversible
Details on [p124](#)



KA21
• 1 bowl sink
• Reversible
Details on [p125](#)



KA22
• 1.5 bowl sink
• Reversible
Details on [p125](#)



KA55
• 1 bowl sink with mini drainer
• Reversible
Details on [p127](#)



KA50
• Compact 1 bowl sink
• Reversible
Details on [p127](#)



KA52
• 1.5 bowl sink
• Reversible
Details on [p128](#)



KA71
• Large 1 bowl sink
• Reversible
Details on [p128](#)



KA82
• 1.5 bowl sink
• Reversible
Details on [p130](#)



KVF21R/L
• 1 bowl flush-fit sink
• Slim top profile
Details on [p131](#)



KVF22R/L
• 1.5 bowl flush-fit sink
• Slim top profile
Details on [p131](#)

Composite



AS1
• Composite 1 bowl sink
• Composite granite construction
• Reversible
• Available in white or cream
Details on [p132](#)



AS2
• Composite 1.5 bowl sink
• Composite granite construction
• Reversible
• Available in white or cream
Details on [p132](#)



KG81
• Composite 1 bowl sink with steel drainer bars
• Granite/quartz construction
• Reversible
• Available in anthracite or graphite
Details on [p135](#)



KG82
• Composite 1.5 bowl sink with steel drainer bars
• Granite/quartz construction
• Reversible
• Available in anthracite or graphite
Details on [p135](#)



KG43
• Composite 1 bowl sink
• Granite/quartz construction
• Reversible
Details on [p133](#)



KG44
• Composite 1.5 bowl sink
• Granite/quartz construction
• Reversible
Details on [p133](#)



KG73
• Composite 1 bowl sink
• Granite/quartz construction
• Reversible
• Available in anthracite or graphite
Details on [p134](#)



KG74
• Composite 1.5 bowl sink
• Granite/quartz construction
• Reversible
• Available in anthracite or graphite
Details on [p134](#)

Ceramic



KC10
• Ceramic Belfast 1 bowl with weir overflow
• Fireclay construction
Details on [p136](#)



KC11
• Ceramic Belfast 1 bowl
• Fireclay construction
Details on [p136](#)



KC12
• Ceramic Belfast 2 bowl
• Fireclay construction
Details on [p137](#)



KC23
• Ceramic 1 bowl sink
• Heavy duty
• Reversible
Details on [p137](#)



KC24
• Ceramic 1.5 bowl sink
• Heavy duty
• Reversible
Details on [p138](#)



KC73
• Ceramic classic design
• 1 bowl sink
• Heavy duty
• Reversible
Details on [p138](#)



KC74
• Ceramic classic design
• 1 bowl sink
• Heavy duty
• Reversible
Details on [p139](#)

Quick guide to undermount sinks

If you are looking for something a little more streamlined, then an undermount sink is the way to go. The sink is designed to fit with your worktops, overlapping the edges, for a seamless finish.

You can still have the option of steel, ceramic or composite. You needn't compromise on size, either, with generous one-and-a-half bowl sizes available.

Stainless steel



KCC21

- 0.5 bowl undermount sink
- Polished finish
- Easy fixing system
- Details on [p141](#)



KCC22

- 3/4 bowl undermount sink
- Polished finish
- Easy fixing system
- Details on [p141](#)



KCC23

- 1 bowl undermount sink
- Polished finish
- Easy fixing system
- Details on [p142](#)



KCC24

- Rectangular 1 bowl undermount sink
- Polished finish
- Easy fixing system
- Details on [p142](#)



KCC27

- 1.5 bowl undermount sink
- Noise-deadening pads
- Easy fixing system
- Details on [p143](#)



KCC28

- 1.5 bowl undermount sink
- Noise-deadening pads
- Easy fixing system
- Details on [p143](#)



KSC21

- 0.5 bowl undermount sink
- Noise-deadening pads
- Easy fixing system
- Details on [p144](#)



KSC22

- 3/4 bowl undermount sink
- Noise-deadening pads
- Details on [p144](#)



KSC23

- 1 bowl undermount sink
- Noise-deadening pads
- Details on [p145](#)



KSC24

- 1 bowl undermount sink
- Noise-deadening pads
- Details on [p145](#)



KSC25

- Large 1 bowl undermount sink
- Noise-deadening pads
- Details on [p146](#)



KVC30R/L

- 1.5 bowl undermount sink
- Noise-deadening pads
- Details on [p146](#)



KVC35R/L

- 1.5 bowl undermount sink
- Noise-deadening pads
- Details on [p147](#)

Composite

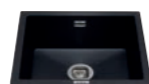

KMG24

- 1 bowl undermount/inset sink
- Tough and hygienic
- Granite/quartz construction
- Available in anthracite or graphite
- Details on [p148](#)



KMG31

- 1.5 bowl undermount/inset sink
- Tough and hygienic
- Granite/quartz construction
- Reversible
- Available in anthracite or graphite
- Details on [p148](#)

Ceramic



KC41

- Ceramic undermount/inset 0.5 bowl sink
- Fireclay construction
- Details on [p149](#)



KC42

- Ceramic undermount/inset 1 bowl sink
- Fireclay construction
- Details on [p149](#)



Inset sinks

In contemporary and traditional finishes, our inset sinks elegantly combine stunning design with versatile functionality.

Stainless steel sinks



KR20

Stainless steel round drainer

Features

- Polished finish

Available in stainless steel

Accessories

- Waste kit
- Plumbing pack

Optional accessories

- Waste disposer, AKD01/AKD02
- Space-saver plumbing pack, PP1

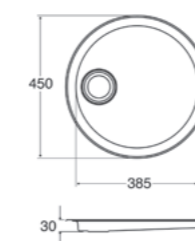

KR21

Stainless steel round single bowl sink

Features

- Polished finish
- Fits in 450mm base unit

Available in stainless steel

Accessories

- Waste kit
- Plumbing pack

Optional accessories

- Waste disposer, AKD01/AKD02
- Space-saver plumbing pack, PP1

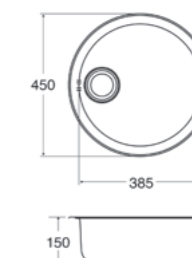

Stainless steel sinks



CCP3

Stainless steel corner double bowl sink

Features

- Polished finish
- 1mm heavy gauge stainless steel construction

Available in stainless steel

Optional accessories

- Waste disposer, AKD01/AKD02
- Space-saver plumbing pack, PP2

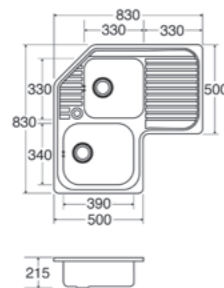

KA20

Stainless steel compact single bowl sink

Features

- Polished finish
- Reversible
- Fits in 450mm base unit

Available in stainless steel

Accessories

- Waste kit
- Plumbing pack

Optional accessories

- Waste disposer, AKD01/AKD02
- Space-saver plumbing pack, PP1

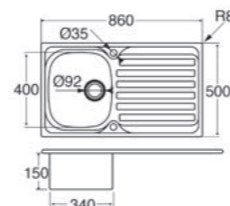

KA21

Stainless steel single bowl sink

Features

- Polished finish
- Reversible
- Fits in 450mm base unit

Available in stainless steel

Accessories

- Waste kit
- Plumbing pack

Optional accessories

- Waste disposer, AKD01/AKD02
- Space-saver plumbing pack, PP1

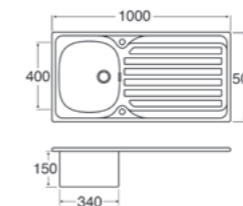

KA22

Stainless steel one-and-a-half bowl sink

Features

- Polished finish
- Reversible
- Fits in 600mm base unit

Available in stainless steel

Accessories

- Waste kit
- Plumbing pack

Optional accessories

- Waste disposer, AKD01/AKD02
- Space-saver plumbing pack, PP2

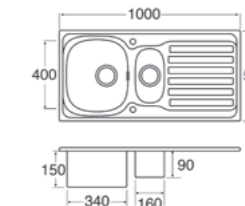

Stainless steel sinks



KA30

Stainless steel compact single bowl sink

Features

- Polished finish
- Reversible
- Fits in 500mm base unit

Available in stainless steel

Accessories

- Waste kit
- Plumbing pack

Optional accessories

- Waste disposer, AKD01/AKD02
- Space-saver plumbing pack, PP1

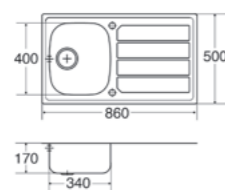

KA32

Stainless steel one-and-a-half bowl sink

Features

- Polished finish
- Reversible
- Fits in 600mm base unit

Available in stainless steel

Accessories

- Waste kit
- Plumbing pack

Optional accessories

- Waste disposer, AKD01/AKD02
- Space-saver plumbing pack, PP2

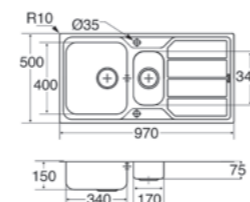

KA55

Stainless steel single bowl sink with mini drainer

Features

- Polished finish
- Reversible
- Fits in 450mm base unit

Available in stainless steel

Accessories

- Waste kit
- Plumbing pack

Optional accessories

- Waste disposer, AKD01/AKD02
- Space-saver plumbing pack, PP1

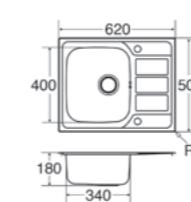

KA50

Stainless steel compact single bowl sink

Features

- Polished finish
- Reversible
- Fits in 450mm base unit

Available in stainless steel

Accessories

- Waste kit
- Plumbing pack

Optional accessories

- Waste disposer, AKD01/AKD02
- Space-saver plumbing pack, PP1

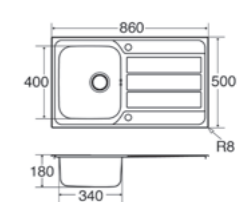

Stainless steel sinks



KA52

Stainless steel one-and-a-half bowl sink

Features

- Polished finish
- Reversible
- Fits in 600mm base unit

Available in stainless steel

Accessories

- Waste kit
- Plumbing pack

Optional accessories

- Waste disposer, AKD01/AKD02
- Space-saver plumbing pack, PP2

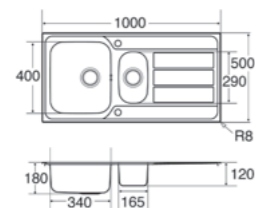

KA71

Stainless steel large single bowl sink

Features

- Polished finish
- Reversible
- Extra large bowl
- Fits in 600mm base unit

Available in stainless steel

Accessories

- Waste kit
- Plumbing pack

Optional accessories

- Waste disposer, AKD01/AKD02
- Space-saver plumbing pack, PP1

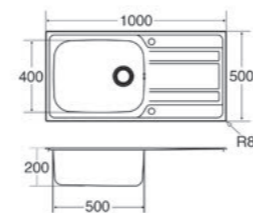

KA72

Stainless steel one-and-a-half bowl sink

Features

- Polished finish
- Reversible
- Fits in 600mm base unit

Available in stainless steel

Accessories

- Waste kit
- Plumbing pack

Optional accessories

- Waste disposer, AKD01/AKD02
- Space-saver plumbing pack, PP2

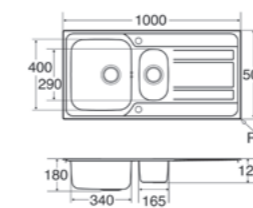

KA80

Stainless steel single bowl sink

Features

- Polished, satinised finish for an extra-smooth, easy-to-clean surface
- Reversible
- Fits in 500mm base unit
- Larger bowl
- Recessed water-safe perimeter profile

Available in stainless steel

Accessories

- Waste kit
- Plumbing pack

Optional accessories

- Waste disposer, AKD01/AKD02
- Space-saver plumbing pack, PP1

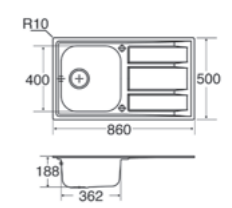

Stainless steel sinks



KA82

Stainless steel one-and-a-half bowl sink

Features

- Polished, satinised finish for an extra-smooth, easy-to-clean surface
- Reversible
- Fits in 600mm base unit
- Recessed water-safe perimeter profile

Available in stainless steel

Accessories

- Waste kit
- Plumbing pack

Optional accessories

- Waste disposer, AKD01/AKD02
- Space-saver plumbing pack, PP2

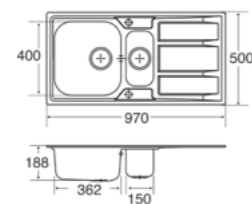

Stainless steel flush-fit sinks



KVF21R



KVF21L

KVF21

Single bowl flush-fit sink

Features

- Extra-large bowl
- Flush-fit, slim top profile
- Fits in 600mm base unit
- 1mm heavy gauge stainless steel construction
- Noise-deadening pads

Available in stainless steel - right-hand drainer, KVF21R; stainless steel - left-hand drainer, KVF21L

Accessories

- Concealed overflow
- Waste kit
- Plumbing pack

Optional accessories

- Waste disposer, AKD01/AKD02
- Space-saver plumbing pack, PP1

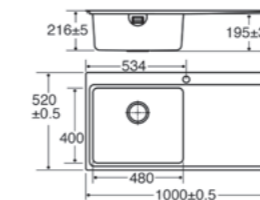

KVF22R



KVF22L

KVF22

One-and-a-half bowl flush-fit sink

Features

- Flush-fit, slim top profile
- Fits in 600mm base unit
- 1mm heavy gauge stainless steel construction
- Noise-deadening pads

Available in stainless steel - right-hand drainer, KVF22R; stainless steel - left-hand drainer, KVF22L

Accessories

- Concealed overflow
- Waste kit
- Plumbing pack

Optional accessories

- Waste disposer, AKD01/AKD02
- Space-saver plumbing pack, PP2

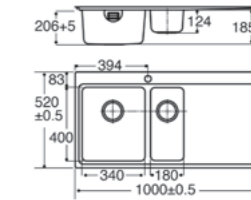

Composite sinks



White



Cream

AS1

Composite single bowl sink

Features

- Composite granite construction
- Scratch resistant
- Reversible
- Fits in 450mm base unit

Available in white, cream

Accessories

- Waste kit
- Plumbing pack

Optional accessories

- Waste disposer, AKD01/AKD02
- Space-saver plumbing pack, PP1

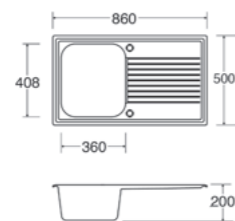

White



Cream

AS2

Composite one-and-a-half bowl sink

Features

- Composite granite construction
- Scratch resistant
- Reversible
- Fits in 600mm base unit

Available in white, cream

Accessories

- Waste kit
- Plumbing pack

Optional accessories

- Waste disposer, AKD01/AKD02
- Space-saver plumbing pack, PP2

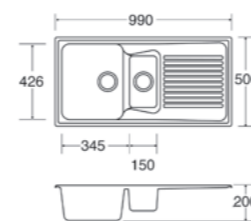

KG43

Composite single bowl sink

Features

- Granite/quartz construction
- Scratch resistant
- Tough and hygienic
- Super smooth metallic finish
- Reversible
- Fits in 600mm base unit
- New and exclusive strainer design

Available in anthracite

Accessories

- Concealed overflow
- Waste kit
- Plumbing pack

Optional accessories

- Waste disposer, AKD01/AKD02
- Space-saver plumbing pack, PP1

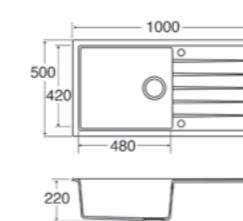

KG44

Composite one-and-a-half bowl sink

Features

- Granite/quartz construction
- Scratch resistant
- Tough and hygienic
- Super smooth metallic finish
- Reversible
- Fits in 600mm base unit
- New and exclusive strainer design

Available in anthracite

Accessories

- Concealed overflow
- Waste kit
- Plumbing pack

Optional accessories

- Waste disposer, AKD01/AKD02
- Space-saver plumbing pack, PP2

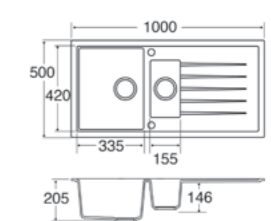

Composite sinks



Anthracite



Graphite

KG73

Composite single bowl sink

Features

- Granite/quartz construction
- Scratch resistant
- Tough and hygienic
- Super smooth metallic finish
- Reversible
- Fits in 600mm base unit
- New and exclusive strainer design

Available in anthracite, graphite

Accessories

- Concealed overflow
- Waste kit
- Plumbing pack

Optional accessories

- Waste disposer, AKD01/AKD02
- Space-saver plumbing pack, PP1

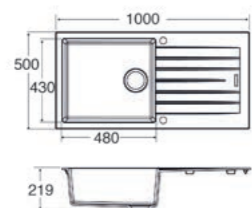

Anthracite



Graphite

KG74

Composite one-and-a-half bowl sink

Features

- Granite/quartz construction
- Scratch resistant
- Tough and hygienic
- Super smooth metallic finish
- Reversible
- Fits in 600mm base unit
- New and exclusive strainer design

Available in anthracite, graphite

Accessories

- Concealed overflow
- Waste kit
- Plumbing pack

Optional accessories

- Waste disposer, AKD01/AKD02
- Space-saver plumbing pack, PP2

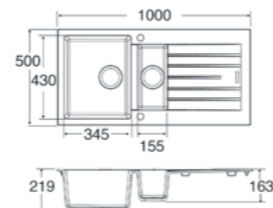

Anthracite



Graphite

KG81

Composite single bowl sink with stainless steel drainer bars

Features

- Granite/quartz construction
- Scratch resistant
- Tough and hygienic
- Super smooth metallic finish
- Reversible
- Fits in 600mm base unit
- New and exclusive strainer design
- Stainless steel drainer bars

Available in anthracite, graphite

Accessories

- Concealed overflow
- Waste kit
- Plumbing pack

Optional accessories

- Waste disposer, AKD01/AKD02
- Space-saver plumbing pack, PP1

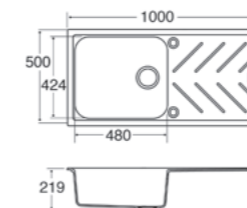

Anthracite



Graphite

KG82

Composite one-and-a-half bowl sink with stainless steel drainer bars

Features

- Granite/quartz construction
- Scratch resistant
- Tough and hygienic
- Super smooth metallic finish
- Reversible
- Fits in 600mm base unit
- New and exclusive strainer design
- Stainless steel drainer bars

Available in anthracite, graphite

Accessories

- Concealed overflow
- Waste kit
- Plumbing pack

Optional accessories

- Waste disposer, AKD01/AKD02
- Space-saver plumbing pack, PP2

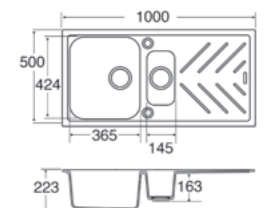

Ceramic sinks



KC10

Ceramic Belfast sink with weir overflow

Features

- Classic design
- Fireclay construction
- Suitable for over or under mounting

Available in white

Accessories

- Waste kit
- Plumbing pack

Optional accessories

- Space-saver plumbing pack, PP1

Combine with
TT56
tap for a true
'Belfast' style

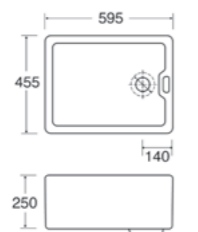

PLEASE NOTE: DIMENSIONS MAY DIFFER BY UP TO 5%



KC11

Ceramic Belfast sink

Features

- Classic design
- Fireclay construction

Available in white

Accessories

- Waste kit
- Plumbing pack

Optional accessories

- Waste disposer and adaptor, AKD01/ AKD02 and AKD03
- Space-saver plumbing pack, PP1

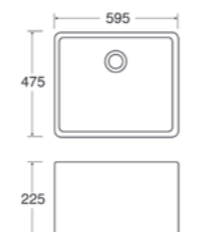

PLEASE NOTE: DIMENSIONS MAY DIFFER BY UP TO 5%



KC12

Ceramic Belfast double bowl sink

Features

- Classic design
- Fireclay construction

Available in white

Accessories

- Waste kit
- Plumbing pack

Optional accessories

- Waste disposer and adaptor, AKD01/ AKD02 and AKD03
- Space-saver plumbing pack, PP2

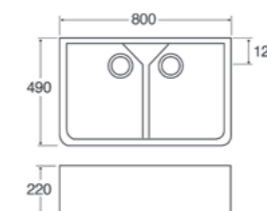

PLEASE NOTE: DIMENSIONS MAY DIFFER BY UP TO 5%



KC23

Ceramic single bowl sink

Features

- Classic design
- Heavy duty
- Reversible
- Fits in 600mm base unit

Available in white

Accessories

- Waste kit
- Plumbing pack

Optional accessories

- Waste disposer and adaptor, AKD01/ AKD02 and AKD03
- Space-saver plumbing pack, PP1

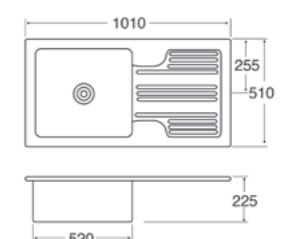

PLEASE NOTE: DIMENSIONS MAY DIFFER BY UP TO 5%

Ceramic sinks

**KC24**

Ceramic one-and-a-half bowl sink

Features

- Classic design
- Heavy duty
- Reversible
- Fits in 600mm base unit

Available in white**Accessories**

- Waste kit
- Plumbing pack

Optional accessories

- Waste disposer and adaptor, AKD01/ AKD02 and AKD03
- Space-saver plumbing pack, PP2

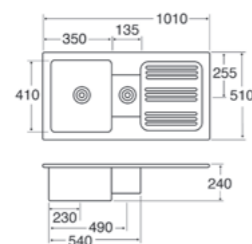

PLEASE NOTE: DIMENSIONS MAY DIFFER BY UP TO 5%

**KC73**

Ceramic single bowl sink

Features

- Classic design
- Heavy duty
- Large bowl
- Reversible
- Fits in 600mm base unit

Available in white**Accessories**

- Waste kit
- Plumbing pack

Optional accessories

- Waste disposer and adaptor, AKD01/ AKD02 and AKD03
- Space-saver plumbing pack, PP1

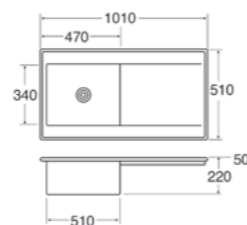

PLEASE NOTE: DIMENSIONS MAY DIFFER BY UP TO 5%

**KC74**

Ceramic one-and-a-half bowl sink

Features

- Classic design
- Heavy duty
- Reversible
- Fits in 600mm base unit

Available in white**Accessories**

- Waste kit
- Plumbing pack

Optional accessories

- Waste disposer and adaptor, AKD01/ AKD02 and AKD03
- Space-saver plumbing pack, PP2

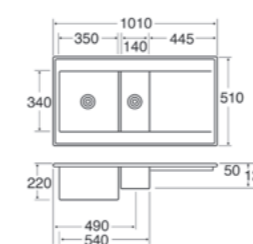

PLEASE NOTE: DIMENSIONS MAY DIFFER BY UP TO 5%

Stainless steel sinks

**KCC21**

Stainless steel undermount half bowl sink

Features

- Polished finish
- Easy fixing system
- Noise-deadening pads

Available in stainless steel

Accessories

- Waste kit
- Plumbing pack

Optional accessories

- Waste disposer, AKD01/AKD02
- Space-saver plumbing pack, PP1

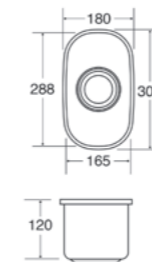
**KCC22**

Stainless steel undermount three-quarter bowl sink

Features

- Polished finish
- Easy fixing system
- Noise-deadening pads

Available in stainless steel

Accessories

- Waste kit
- Plumbing pack

Optional accessories

- Waste disposer, AKD01/AKD02
- Space-saver plumbing pack, PP1

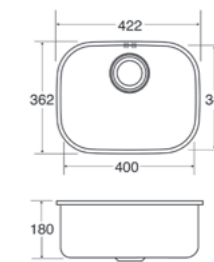

Undermount sinks

Our undermount sinks blend seamlessly with your worktop surround to create a flawless finish.

Stainless steel sinks



KCC23

Stainless steel undermount single bowl sink

Features

- Polished finish
- Easy fixing system
- Noise-deadening pads

Available in stainless steel

Accessories

- Waste kit
- Plumbing pack

Optional accessories

- Waste disposer, AKD01/AKD02
- Space-saver plumbing pack, PP1

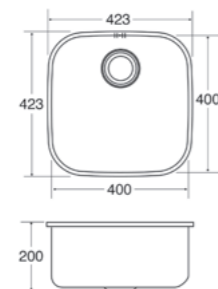

KCC24

Stainless steel undermount rectangular single bowl sink

Features

- Polished finish
- Easy fixing system
- Noise-deadening pads

Available in stainless steel

Accessories

- Waste kit
- Plumbing pack

Optional accessories

- Waste disposer, AKD01/AKD02
- Space-saver plumbing pack, PP1

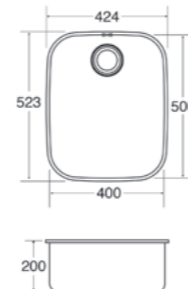

KCC27

Stainless steel undermount right-hand one-and-a-half bowl sink

Features

- Polished finish
- Easy fixing system
- Noise-deadening pads

Available in stainless steel

Accessories

- Waste kit
- Plumbing pack

Optional accessories

- Waste disposer, AKD01/AKD02
- Space-saver plumbing pack, PP2

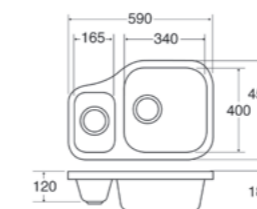

KCC28

Stainless steel undermount left-hand one-and-a-half bowl sink

Features

- Polished finish
- Easy fixing system
- Noise-deadening pads

Available in stainless steel,

Accessories

- Waste kit
- Plumbing pack

Optional accessories

- Waste disposer, AKD01/AKD02
- Space-saver plumbing pack, PP2

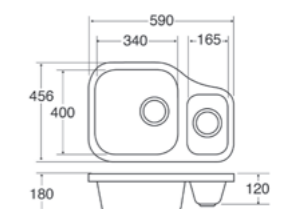

Stainless steel sinks



KSC21

Stainless steel undermount half bowl sink

Features

- 1mm heavy gauge stainless steel construction
- Noise-deadening pads
- Square strainer design

Available in stainless steel

Accessories

- Concealed overflow
- Waste kit
- Plumbing pack

Optional accessories

- Space-saver plumbing pack, PP1

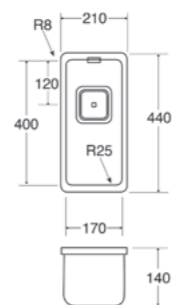

KSC22

Stainless steel undermount three-quarter bowl sink

Features

- 1mm heavy gauge stainless steel construction
- Noise-deadening pads
- Square strainer design

Available in stainless steel

Accessories

- Concealed overflow
- Waste kit
- Plumbing pack

Optional accessories

- Space-saver plumbing pack, PP1



KSC23

Stainless steel undermount single bowl sink

Features

- 1mm heavy gauge stainless steel construction
- Noise-deadening pads
- Square strainer design

Available in stainless steel

Accessories

- Concealed overflow
- Waste kit
- Plumbing pack

Optional accessories

- Space-saver plumbing pack, PP1

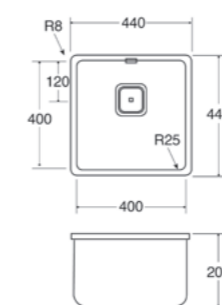

KSC24

Stainless steel undermount single bowl sink

Features

- 1mm heavy gauge stainless steel construction
- Noise-deadening pads
- Square strainer design

Available in stainless steel

Accessories

- Concealed overflow
- Waste kit
- Plumbing pack

Optional accessories

- Space-saver plumbing pack, PP1

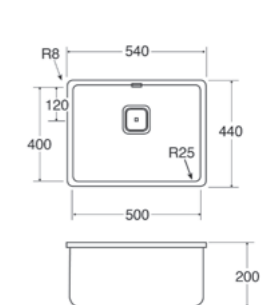

Stainless steel sinks



KSC25

Stainless steel undermount large single bowl sink

Features

- 1mm heavy gauge stainless steel construction
- Noise-deadening pads
- Square strainer design

Available in stainless steel

Accessories

- Concealed overflow
- Waste kit
- Plumbing pack

Optional accessories

- Space-saver plumbing pack, PP1

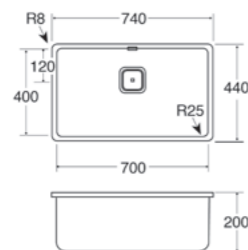

KVC30R



KVC30L

KVC30

Stainless steel undermount one-and-a-half bowl sink

Features

- Satin finish
- Noise-deadening pads
- Exclusive strainer design

Available in stainless steel - right-hand half bowl, KVC30R; stainless steel - left-hand half bowl, KVC30L

Accessories

- Concealed overflow
- Waste kit
- Plumbing pack

Optional accessories

- Waste disposer, AKD01/AKD02
- Space-saver plumbing pack, PP2

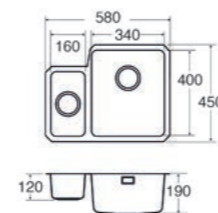

KVC35R



KVC35L

KVC35

Stainless steel undermount one-and-a-half bowl sink

Features

- Satin finish
- Noise-deadening pads
- Exclusive strainer design

Available in stainless steel - right-hand half bowl, KVC35R; stainless steel - left-hand half bowl, KVC35L

Accessories

- Concealed overflow
- Waste kit
- Plumbing pack

Optional accessories

- Waste disposer, AKD01/AKD02
- Space-saver plumbing pack, PP2

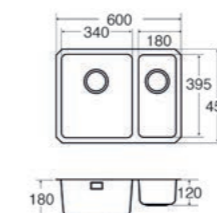

Composite sinks



Anthracite



Graphite

KMG24

Composite undermount/inset single bowl sink

Features

- Granite/quartz construction
- Tough and hygienic
- Super smooth metallic finish
- Reversible
- Fits in 600mm base unit
- Exclusive strainer design
- Both undermount and inset clips included
- Can be undermount or inset

Available in anthracite, graphite

Accessories

- Concealed overflow
- Waste kit
- Plumbing pack

Optional accessories

- Waste disposer, AKD01/AKD02
- Space-saver plumbing pack, PP1

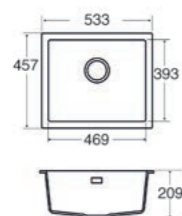

Anthracite



Graphite

KMG31

Composite undermount/inset one-and-a-half bowl sink

Features

- Granite/quartz construction
- Tough and hygienic
- Super smooth metallic finish
- Reversible
- Fits in 600mm base unit
- Exclusive strainer design
- Both undermount and inset clips included
- Can be undermount or inset

Available in anthracite, graphite

Accessories

- Concealed overflow
- Waste kit
- Plumbing pack

Optional accessories

- Waste disposer, AKD01/AKD02
- Space-saver plumbing pack, PP2

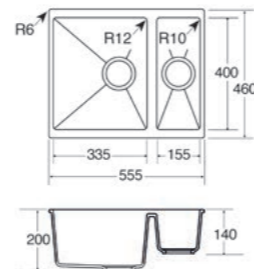

Ceramic sinks



KC41

Ceramic undermount/inset half bowl sink

Features

- Classic design
- Fireclay construction
- Can be undermount or inset

Available in white

Accessories

- Waste kit
- Plumbing pack

Optional accessories

- Waste disposer and adaptor, AKD01/AKD02 and AKD03
- Space-saver plumbing pack, PP1

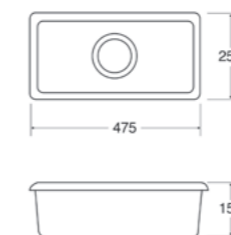

PLEASE NOTE: DIMENSIONS MAY DIFFER BY UP TO 5%



KC42

Ceramic undermount/inset half bowl sink

Features

- Classic design
- Fireclay construction
- Can be undermount or inset

Available in white

Accessories

- Waste kit
- Plumbing pack

Optional accessories

- Waste disposer and adaptor, AKD01/AKD02 and AKD03
- Space-saver plumbing pack, PP1

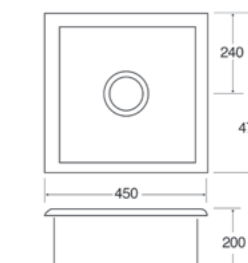

PLEASE NOTE: DIMENSIONS MAY DIFFER BY UP TO 5%



Taps

Whether it's a simple lever tap or something more sophisticated, if you choose a tap from our 2020 collection you can be sure that it will be beautifully designed.

Filter tap

Our **TF55** tap filters mains tap water to improve its taste, clarity and odour. Mains water is passed through a cartridge concealed under the sink and is controlled through the tap by a simple lever action.

Hot water on demand

Speed up cooking and making hot drinks by installing a **TH102** instant hot water tap. With an under-counter heating tank, this useful kitchen appliance can produce around 1.8 litres of hot water per minute, supporting many culinary tasks.

Professional chef-style taps

The pull-out spray on some of our contemporary taps can be a useful helping hand. Use the spray for thorough rinsing of fruit and vegetables, for fast defrosting, to fill large vases or buckets, and for countless other kitchen jobs.

Quick guide to taps

The range of taps from CDA covers a wide spectrum of designs, from stylish, functional taps through to cutting-edge, contemporary designer taps that make a bold statement in your kitchen.

Contemporary taps



TC10

- Standard single lever tap
Details on [p154](#)

TC15

- Classic single lever tap
Details on [p154](#)

TC20

- Standard quarter turn monobloc tap
Details on [p154](#)



TC28

- Contemporary quarter turn monobloc tap
Details on [p155](#)

TC31

- Single side lever tap with swan neck spout
Details on [p155](#)

TC41

- Quarter turn cross handle monobloc tap
Details on [p155](#)

TC55

- Monobloc tap with swan neck spout
Details on [p156](#)

TC57

- Side single lever tap with swan neck spout
Details on [p156](#)



TC61

- Side single lever tap with quad spout
Details on [p156](#)

TC65

- Monobloc tap with quad spout
Details on [p157](#)

TC66

- Side single lever tap with quad spout
Details on [p157](#)



TC77

- Contemporary slant monobloc tap
Details on [p157](#)

TV5

- Contemporary side single lever tap
Details on [p158](#)

TV6

- Round tower single lever tap
Details on [p158](#)

TV7

- Contemporary side single lever tap with swivel spout
Details on [p158](#)

TV9

- Contemporary square side single lever tap
Details on [p159](#)

Traditional taps



TT25

- Traditional monobloc tap
Details on [p160](#)

TT41

- Traditional turn lever monobloc tap
Details on [p160](#)

TT50

- Traditional dual lever monobloc tap
Details on [p160](#)



TT56

- Traditional quarter turn bridge mixer tap
Details on [p161](#)

Guidance on minimum operation pressure

Taps with a minimum operating pressure of 0.4Bar, or less, are compatible with low pressure hot water systems.

Check your supply pressure before purchasing taps requiring 0.5Bar or higher.

Filter tap



TF55

- Monobloc filter tap with swan neck spout
Details on [p161](#)

3-in-1 tap



TH102

- 3-in-1 instant hot water tap
Details on [p163](#)

Pull-out taps



TC56

- Traditional quarter turn bridge mixer tap
Details on [p162](#)

TM1

- Contemporary single lever tap with pull-out spray
Details on [p162](#)

TV11

- Single lever tap with black pull-out spray
Details on [p162](#)

TV14

- Single lever tap with pull-out spout
Details on [p163](#)

Contemporary taps



TC10

Standard single lever tap

Features

- Single flow
- Minimum pressure: **0.5Bar**
- 360° spout rotation
- Ceramic disc valve

Available in chrome

Accessories

- Supplied with flexible tail pipes

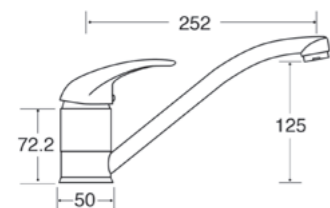

TC15

Classic single lever tap

Features

- Single flow
- Minimum pressure: **0.3Bar**
- WRAS approved
- Ceramic single lever valve

Available in chrome

Accessories

- Supplied with rigid copper tail pipes

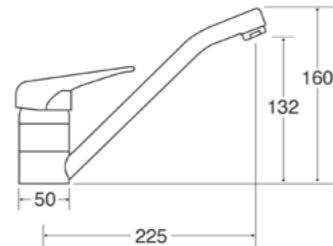

TC20

Standard quarter turn monobloc tap

Features

- Single flow
- Minimum pressure: **0.1Bar**
- 360° spout rotation
- Ceramic disc 1/4 turn valves

Available in chrome

Accessories

- Supplied with flexible tail pipes

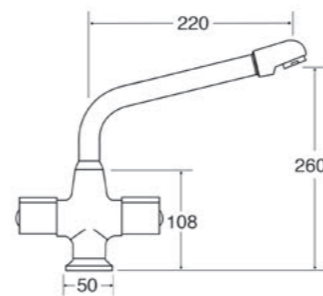

TC28

Contemporary quarter turn monobloc tap

Features

- Single flow
- Minimum pressure: **0.4Bar**
- Ceramic disc 1/4 turn valves
- 360° spout rotation

Available in chrome

Accessories

- Supplied with flexible tail pipes

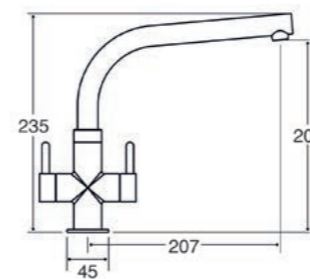

TC31

Single side lever tap with swan neck spout

Features

- Solid stainless steel
- Single flow
- Minimum pressure **0.5Bar**
- Ceramic single lever valve
- 360° spout rotation

Available in stainless steel

Accessories

- Supplied with flexible tail pipes

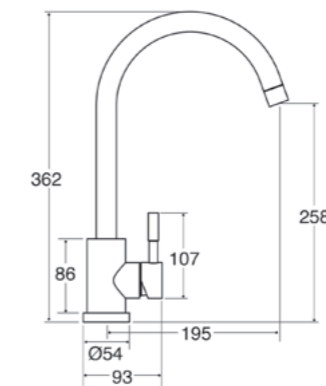

TC41

Quarter turn cross handle monobloc tap

Features

- Dual flow
- Minimum pressure: **0.3Bar**
- WRAS approved
- Ceramic disc 1/4 turn valves

Available in chrome

Accessories

- Supplied with rigid copper tail pipes

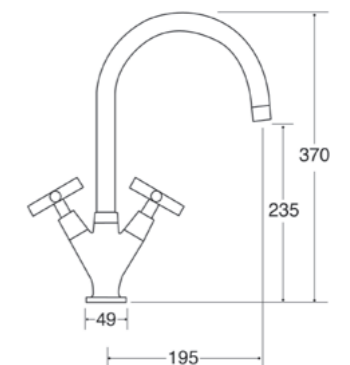

Contemporary taps



TC55

Monobloc tap with swan neck spout

Features

- Dual flow
- Minimum pressure: **0.3Bar**
- WRAS approved
- Ceramic disc 1/4 turn valves

Available in chrome, nickel

Accessories

- Supplied with rigid copper tail pipes

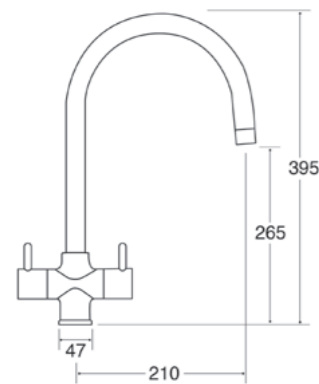

TC57

Side single lever tap with swan neck spout

Features

- Single flow
- Minimum pressure: **0.5Bar**
- Ceramic single lever valve

Available in chrome

Accessories

- Supplied with flexible tail pipes

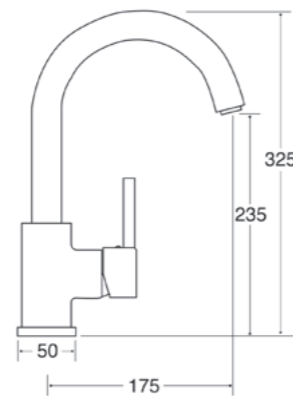

TC61

Side single lever tap with quad spout

Features

- Single flow
- Minimum pressure: **0.5Bar**
- 360° spout rotation
- Ceramic disc valve

Available in stainless steel

Accessories

- Supplied with flexible tail pipes

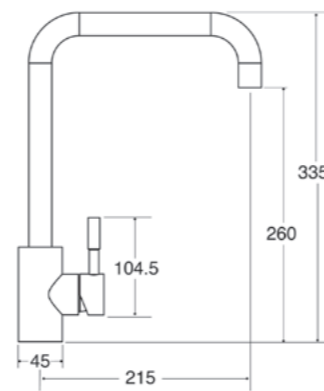

TC65

Monobloc tap with quad spout

Features

- Dual flow
- Minimum pressure: **0.3Bar**
- Ceramic disc 1/4 turn valves

Available in chrome

Accessories

- Supplied with rigid copper tail pipes

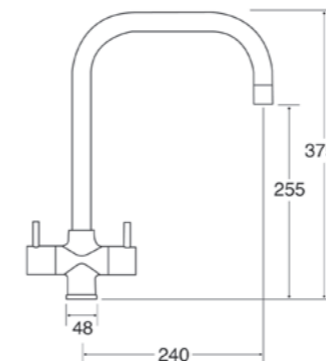

TC66

Side single lever tap with quad spout

Features

- Single flow
- Minimum pressure: **0.5Bar**
- Ceramic single lever valve

Available in chrome

Accessories

- Supplied with flexible tail pipes

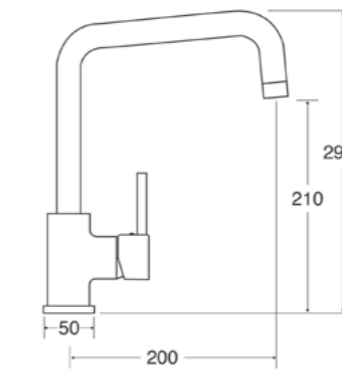

TC77

Contemporary slant monobloc tap

Features

- Single flow
- Minimum pressure: **0.5Bar**
- WRAS approved
- 360° spout rotation
- Ceramic disc 1/4 turn valves

Available in chrome

Accessories

- Supplied with flexible tail pipes

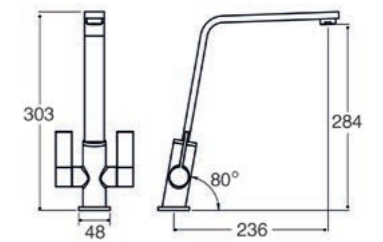

Contemporary taps



TV5

Contemporary side single lever tap

Features

- Single flow
- Minimum pressure: **0.5Bar**
- 360° spout rotation
- Ceramic disc single lever valve

Available in chrome

Accessories

- Supplied with flexible tail pipes

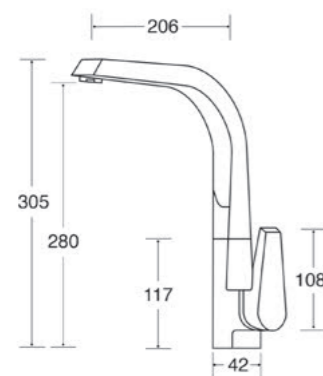

TV6

Round tower single lever tap

Features

- Single flow
- Minimum pressure: **0.5Bar**
- 360° spout rotation
- Ceramic disc single lever valve

Available in chrome

Accessories

- Supplied with flexible tail pipes

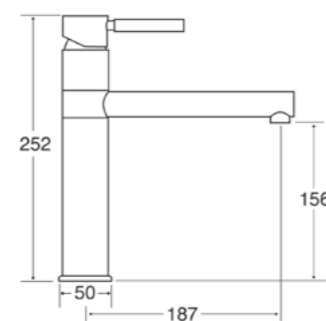

TV7

Contemporary side single lever tap with swivel spout

Features

- Single flow
- Minimum pressure: **0.75Bar**
- 360° spout rotation
- Swivel aerator for precise flow control
- Ceramic disc single lever valve

Available in chrome

Accessories

- Supplied with flexible tail pipes

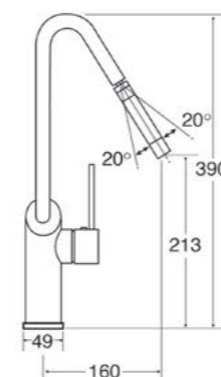

TV9

Contemporary square side single lever tap

Features

- Single flow
- Minimum pressure: **0.5Bar**
- WRAS approved
- 360° spout rotation
- Ceramic disc single lever valve

Available in chrome, matt black

Accessories

- Supplied with flexible tail pipes

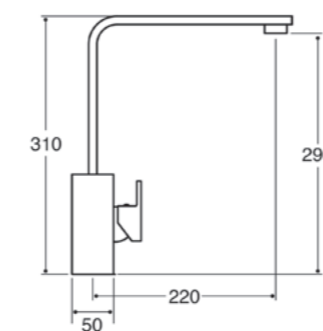

Traditional taps

**TT25**

Traditional monobloc tap

Features

- Dual flow
- Minimum pressure: **0.3Bar**
- WRAS approved
- Compression valves

Available in chrome**Accessories**

- Supplied with rigid copper tail pipes

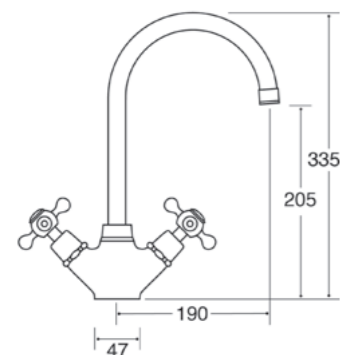
**TT41**

Traditional quarter turn lever monobloc tap

Features

- Dual flow
- Minimum pressure: **0.2Bar**
- WRAS approved
- Ceramic disc 1/4 turn valves

Available in chrome, nickel**Accessories**

- Supplied with rigid copper tail pipes

Optional accessories

- Interchangeable handles:
 - White/chrome, **ATT01WH**
 - White/nickel, **ATT02WH**
 - Black/chrome, **ATT01BL**
 - Black/nickel, **ATT02BL**

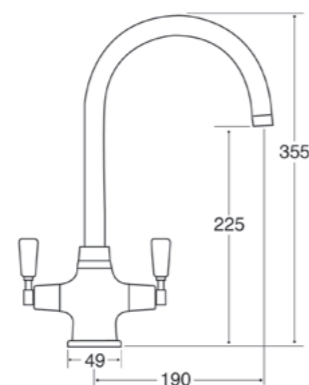
**TT50**

Traditional dual lever monobloc tap

Features

- Single flow
- Minimum pressure: **0.5Bar**
- 360° spout rotation
- Ceramic disc 1/4 turn valves

Available in chrome**Accessories**

- Supplied with flexible tail pipes

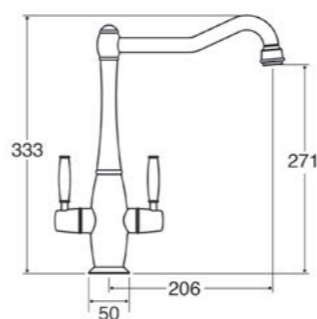
**TT56**

Traditional quarter turn bridge mixer tap

Features

- Single flow
- Minimum pressure: **0.3Bar**
- Ceramic disc 1/4 turn valves

Available in chrome**Accessories**

- Supplied with adjustable inlet pipes

Optional accessories

- Interchangeable handles:
 - White/chrome, **ATT01WH**
 - Black/chrome, **ATT01BL**

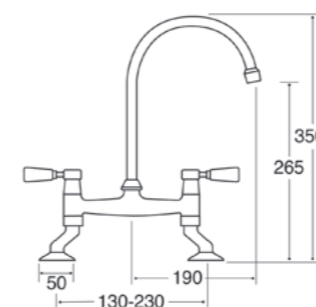

Filter tap

**TF55**

Monobloc filter tap with swan neck spout

Features

- Dual flow
- Minimum pressure: **0.4Bar**
- 2 way ceramic disc valve
- WRAS approved

Available in chrome**Accessories**

- Filter and installation kit
- Supplied with rigid copper tail pipes

Optional accessories

- Replacement filter, **ATF001**

Fitting note

- We recommend that you replace the filter every six months

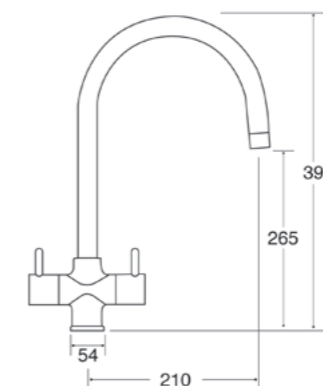

Pull-out taps



TC56

Monobloc tap with pull-out spout

Features

- Single flow
- Minimum pressure: **0.75Bar**
- Pull-out spout
- Ceramic disc 1/4 turn valves
- Hose extends up to 500mm

Available in chrome

Accessories

- Supplied with rigid copper tail pipes

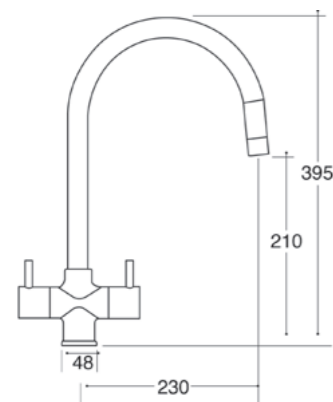

TM1

Contemporary single lever tap with pull-out spray

Features

- Single flow
- Minimum pressure: **1Bar**
- Pull-out spray
- Ceramic disc valve

Available in chrome

Accessories

- Supplied with flexible tail pipes

Fitting note

- Please ensure that your supply pressure is adequate

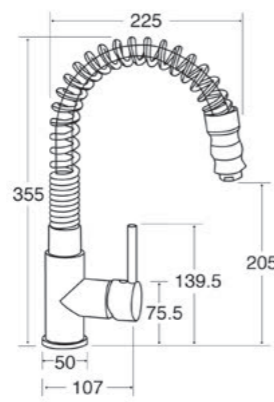

TV11

Single lever tap with black pull-out spray

Features

- Solid stainless steel construction
- Single flow
- Minimum pressure: **1.5Bar**
- Pull-out spray
- 360° spout rotation
- Ceramic disc valve

Available in stainless steel

Accessories

- Supplied with flexible tail pipes

Fitting note

- Please ensure that your supply pressure is adequate

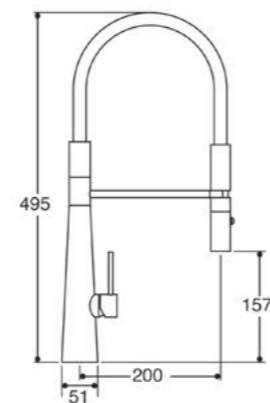

TV14

Single lever tap with pull-out spout

Features

- Single flow
- Minimum pressure: **0.7Bar**
- 360° spout rotation
- Pull-out spray

Available in brushed steel/black, brushed steel/grey, brushed steel/white

Accessories

- Supplied with flexible tail pipes

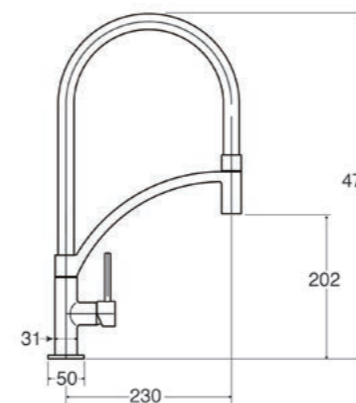

3-in-1 tap



TH102

3-in-1 instant hot water tap



Features

- Non-pressurised tank for increased reliability
- Minimum pressure: **1.5Bar**
- Maximum pressure: **5.5Bar**
- 360° spout rotation
- 2.1L tank
- Filter included
- Rapid 9 minutes initial heat up from cold supply
- Allows several cups of 98°C water to be dispensed
- Easy descaling

Available in chrome or brushed steel finish

Accessories

- Supplied with flexible tail pipes

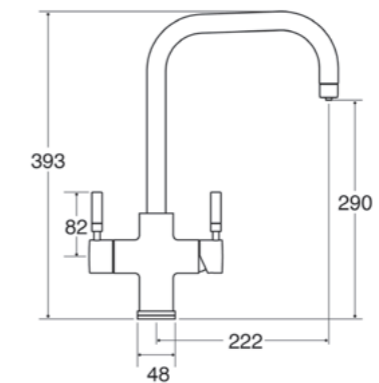

Optional accessories

- Replacement filter
- Descaling solution

Fitting note

- Please ensure that your supply pressure is adequate
- We recommend changing the filter and descaling the boiler every 6 months

5
YEARS
PARTS
2 YEARS LABOUR



Accessories

From tap handles and stylish splashbacks to the vital bits that make everything work perfectly, our accessories section provides all the important finishing touches.

Extractor accessories

Find the ducting kit and charcoal filters for your chosen extractor.

Sink accessories

Waste dispensers and plumbing packs that are compatible with our sink range.

Dishwasher accessories

Add a Variospace wine glass holder for even more versatility.

Chilled beverage accessories

Get glass shelving and attachments for our wine coolers, and stylish tap handles for our chilled beer dispenser.

Splashbacks

Save your walls from the inevitable splashes and spills with a splashback. Choose from a range of attractive finishes to match the design of your kitchen.

Extractor accessories

Ducting kits

Image	Code	Description
	AED51	<p>125mm x 1m flexible ducting kit</p> <ul style="list-style-type: none"> • White wall outlet • 2 cable ties • 1m flexible hose • Fixing kit
	AED53	<p>125mm x 6m flexible ducting kit</p> <ul style="list-style-type: none"> • White wall outlet • 2 cable ties • 6m flexible hose • Fixing kit
	AED54	<p>125mm x 3m rigid ducting kit</p> <ul style="list-style-type: none"> • White wall outlet • 2 x 1m rigid ducting • 500mm rigid ducting • Wall plate • Connector • 125mm elbow bend • 2 threaded hose connectors • 1m flexible hose • Horizontal bend • Fixing kit
	AED61	<p>150mm x 1m flexible ducting kit</p> <ul style="list-style-type: none"> • White wall outlet • 2 cable ties • 1m flexible hose • Fixing kit
	AED63	<p>150mm x 6m flexible ducting kit</p> <ul style="list-style-type: none"> • White wall outlet • 2 cable ties • 6m flexible hose • Fixing kit
	AED 64	<p>150mm x 3m rigid ducting kit</p> <ul style="list-style-type: none"> • White wall outlet • 2 x 1m rigid ducting • 350mm rigid round ducting • Wall plate • Connector • 125mm elbow bend • 2 threaded hose connectors • 1m flexible hose • Horizontal bend • Round-to-rectangular adapter • Fixing kit

Extractor accessories

Filters

Code	Contents	Compatible with
CHA12	Charcoal filter (pack of 1)	ECN62/72/92, ECP62/72/82/92/102/112, EKP90, ECNK90, EVX90, EDD62, EDD92
CHA14	Charcoal filter (pack of 2)	3D9, EXA60/80
CHA15	Charcoal filter (pack of 1)	EIN60, EVA60/70/90, ECA60, CCA52, CCA72
CHA17	Charcoal filter (pack of 2)	EKP60/70/90, EKN60/70/90
CHA21	Charcoal filter (pack of 2)	EVG6/9, EVP61/91/101/121, EVPK90
CHA24	Charcoal filter (pack of 2)	ECH61/71/91/101
CHA25	Charcoal filter (pack of 2)	ECHK90, ECPK90, ECR90
CHA28	Charcoal filter (pack of 2)	HNE8
CHA33	Charcoal filter (pack of 2)	EVQ71
CHA34	Charcoal filter (pack of 2)	CTE61
CHA35	Charcoal filter (pack of 2)	CTE9
CHA36	Charcoal filter (pack of 1)	CST61
GRE1	Acrylic grease filter	EIN60
GRE3M	Metal grease filter	EIN60
RTP01	Re-circulating T-piece	EXA60/80

Sink accessories

Waste disposers

Our convenient waste disposers are easy to install, cheap to run and require no regular maintenance. They help save time, whilst being both smell- and mess-free.

Code	Description	Compatible with
AKD01	380W waste disposer	All sinks except KSC models and KC10
AKD02	550W waste disposer	All sinks except KSC models and KC10
AKD03	Waste disposer adapter	All ceramic sinks (except KC10) using AKD01 or AKD02

Plumbing packs

Code	Contents	Compatible with
PP1	Space-saver plumbing pack	All single bowl sinks
PP2	Space-saver plumbing pack	All one-and-a-half bowl sinks

Dishwasher accessories

Dishwasher wine glass holder

Code	Description	Compatible with
AWG100	Variospace wine glass holder	WC600, WC480, WC371

Wine cooler accessories

Wine cooler glass shelves

Our wine cooler glass shelves are perfect for storing smaller items such as bottles and cans.

Code	Description	Compatible with
AFG31	Glass shelves (pack of 3)	FWC304, FWC624
AFG61	Glass shelves (pack of 3)	FWC604, FWC881
AFJ61	Steel frame, plinth and joining strips	FWC861

Beer dispenser accessories

Tap handles

TT41 tap handles

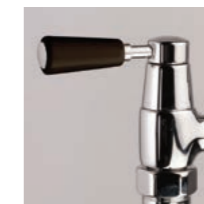

TT56 tap handles



Code	Description	Compatible with
ATT01BL	Black tap handles	TT41CH, TT56CH
ATT01WH	White tap handles	TT41CH, TT56CH
ATT02BL	Black tap handles	TT41NI
ATT02WH	White tap handles	TT41NI

Other accessories

Code	Description	Compatible with
ABC001	G-style keg connector (to be sold with ABC004)	BVB4
ABC002	CO ² bottle (filled)	BVB4
ABC003	Cleaning tablets (pack of 10)	BVB4
ABC004	G-style cleaning connector (to be sold with ABC001)	BVB4
ABC005	A-style keg connector (to be sold with ABC006)	BVB4
ABC006	A-style cleaning connector (to be sold with ABC005)	BVB4

Splashback accessories

Splashbacks



Square glass splashback



Square metal splashback

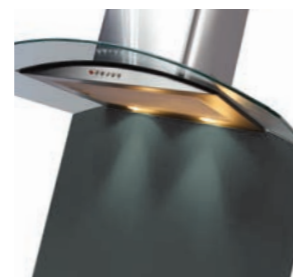

Curved glass splashback

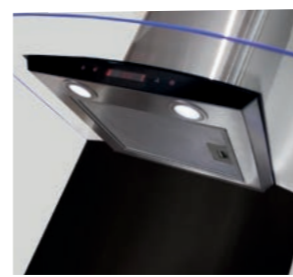

Curved metal splashback

Accessories

Square glass splashbacks

Black	Grey	Description
ASG6BL	ASG6GR	600W x 750H* square toughened glass
ASG7BL	ASG7GR	700W x 750H* square toughened glass
ASG9BL	ASG9SS	900W x 750H* square toughened glass
ASG10BL	ASG10GR	1000W x 750H* square toughened glass
ASG12BL	ASG12GR	1200W x 750H* square toughened glass

Square metal splashbacks

Black	Stainless steel	Description
CSB6BL	CSB6SS	600W x 750H square metal
CSB7BL	CSB7SS	700W x 750H square metal
CSB9BL	CSB9SS	900W x 750H square metal
CSB10BL	CSB10SS	1000W x 750H square metal

Curved glass splashbacks

Designed to match the ECP and EKP range of extractors

Black	Grey	Description	Compatible with
ASG62CBL	ASG62CGR	600W x 750H* curved glass	ECP62, EKP60
ASG72CBL	ASG72CGR	700W x 750H* curved glass	ECP72, EKP70
ASG82CBL	ASG82CGR	800W x 750H* curved glass	ECP82
ASG92CBL	ASG92CGR	900W x 750H* curved glass	ECP92
ASG92KBL	ASG92KGR	900W x 750H* curved glass	ECP80
ASG102CBL	ASG102CGR	1000W x 750H* curved glass	ECP102
ASG112CBL	ASG112CGR	1100W x 750H* curved glass	ECP112

Curved metal splashbacks

Designed to match the ECP and EKP range of extractors

Black	Stainless steel	Description	Compatible with
CSB62CBL	CSB62CSS	600W x 750H curved metal	ECP62, EKP60
CSB72CBL	CSB72CSS	700W x 750H curved metal	ECP72, EKP70
CSB92CBL	CSB92CSS	900W x 750H curved metal	ECP92
CSB92KBL	CSB92KSS	900W x 750H curved metal	EKP60

*Our toughened glass splashbacks are handmade, so dimensions shown may vary by up to 5mm

Accessories

Ceramic filter

Code	Description	Compatible with
ATF001	Ceramic filter	TF55

Flow rate restrictors

Code	Description	Compatible with
ATF002	Flow rate restrictors*	All taps with rigid copper tail pipes
ATF003	Flow rate restrictors*	All taps with flexible tail pipes

Hob accessories

Code	Description	Compatible with
AHJ30	Domino joining strip	All stainless steel domino hobs (excludes HE3140)

Plinth heater



Code	Description
APH02SS	Electric 2kW plinth heater



Stay up-to-date

You can locate your nearest CDA retailer, register your purchase or contact our customer care team on our website.

From time to time our products are changed, specifications updated and new products launched. Visit our website for all up-to-date information and specifications.

Discover our appliances at www.cda.eu

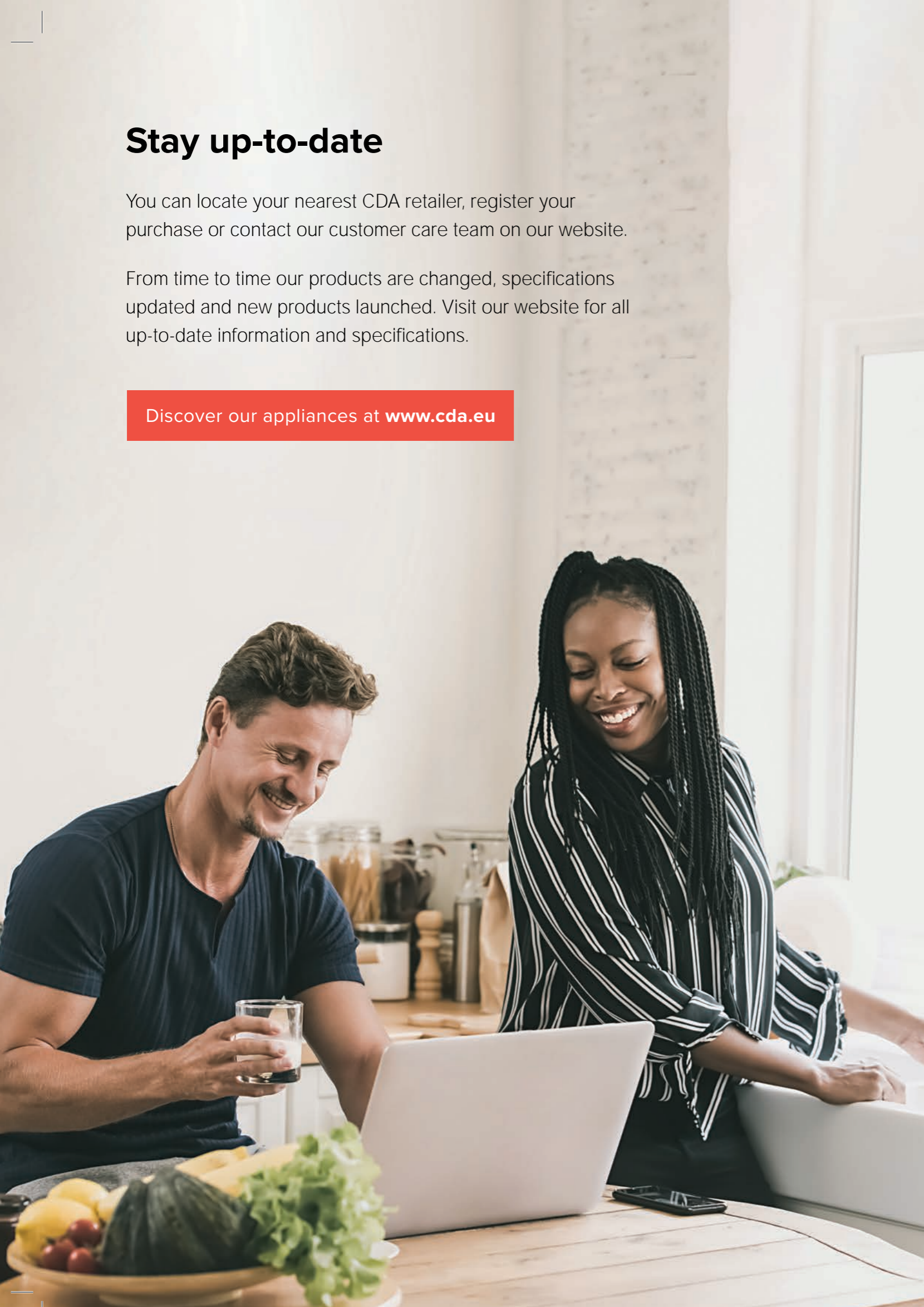

Terms and conditions of warranty

- Parts are defined as mechanical/electrical parts only.
- Products registered outside of the 60 day period will receive 12 months parts and labour. The 60 day period is calculated from the purchase date and not the delivery/installation date
- Proof of date of purchase must be provided to activate the warranty, and before an engineer visit can be arranged.
- To qualify for free parts they must be fitted by a CDA appointed engineer.
- Any attempts to modify or repair an appliance by an unauthorised person will render all warranties invalid.
- A charge will be made for attending a reported fault that transpires to be due to misuse or mis-installation.
- CDA retains the right to invalidate the guarantee in the event of physical or verbal abuse towards any member of staff.
- CDA warranties cover domestic use only - commercial use is not covered.
- Warranties in whole or part are not transferable.
- Taps – during the first year, at our discretion we may pay for refitting (on receipt of the faulty part/tap, once inspected and deemed faulty) up to a maximum defined cost.
- The provision of services under the warranty neither extends the term of the warranty nor sets in motion a new warranty period. The warranty period for spare parts fitted ends with the expiry of the warranty on the appliance as a whole. The warranty remains effective from the date of purchase.
- On the occasion that a product is over 2 years old* and is considered to be beyond repair, or uneconomical to repair, then we will offer a replacement appliance and charge an appropriate monetary offset in respect of the period of use already enjoyed.
- Warranties apply in the UK and Southern Ireland only.

What is not covered























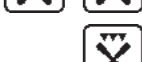

- Transport damage for which CDA is not responsible.
- Improper installation and assembly.
- Faults due to accidental damage or misuse.
- Gas leaks not related to a CDA appliance.
- Improper use including where an appliance has been used in a non-domestic environment, or poor maintenance, or failure to observe the operating instructions.
- Damage caused by the appliance coming into contact with unsuitable materials.
- Claims in respect of compensation for consequential loss, except where such liability is legally mandatory.
- Consumables and cosmetic parts such as glass, bulbs, seals, fuses, filters, external hoses, cosmetic parts, baskets, trays, burner caps, burner bases etc.
- Damage to, or during, the replacement of any light bulbs or removable parts of glass and plastic.
- TH101 3-in-1 instant hot water tap is guaranteed for 2 year parts and 2 year labour.
- Gas leaks not related to a CDA appliance

Details of extended warranties are available on request.

The table below shows where the warranty is restricted due to non-domestic conditions:

	5 years parts, 2 years labour	2 years parts, 2 years labour	1 year parts, 1 year labour
Normal domestic sale and use	✓		
Rental or service apartment (non-students)		✓	
Students (communal living and non-communal), not new build		✓	
Students (communal living and non-communal), new build		✓	
Students (non-communal), one student per kitchen	✓		
Semi-commercial, e.g. school domestic science lab			✓

E & O E • ALL DIMENSIONS AND ILLUSTRATIONS ARE PROVIDED FOR GUIDANCE ONLY. CDA RESERVE THE RIGHT TO CHANGE SPECIFICATIONS WITHOUT PRIOR NOTICE. WEEE PRODUCER REGISTRATION NUMBER: WEE/FD0074UR.

-  Oven light
-  Defrost
-  Conventional oven
-  Eco-conventional oven
-  Fan-assisted oven
-  Fan oven
-  Eco-fan oven
-  Fan cooking with lower heat
-  Fan cooking with upper heat
-  Fan with lower heat
-  Browning oven
-  Warming oven
-  Grill/half grill
-  Half-fanned electric grill
-  Fanned electric grill
-  Steam cooking
-  Eco-clean
-  Aqualytic cleaning function
-  Pyrolytic cleaning
-  Gas oven
-  Fanned gas oven
-  Microwave function
-  Microwave and grill function
-  Microwave and fan oven
-  Rapid preheat
-  Steam cleaning